



Baseball Ontario appreciates the support of our sponsors:

PLATINUM

Mizuno Canada
Toronto Blue Jays
Worth/Rawlings

DIAMOND

Homerun Sports
Visportsclub.com

GOLD

Combat Sports
H&R Block
Silverstar Sports

BRONZE

Elite Athletic Health
Extra Bases
Homerun Baseball Academy
Hutcheson Sand & Mixes
Marchant's School Sport Ltd.
Marco Clay Products
Sportsphere
World's Finest Chocolate
Xtra Innings

ONTARIO BASEBALL ASSOCIATION INC.

FORMERLY KNOWN AS

ONTARIO BASEBALL AMATEUR ASSOCIATION

(Organized May 4th, 1918)

The Ontario Baseball Amateur Association was organized at a meeting held in the Central YMCA, Hamilton, on Saturday, May 4th, 1918.

Charter Members

**Toronto Amateur Baseball Association
Hamilton Amateur Baseball Association
Brantford City League
Oshawa Town League
Kitchener City League
Dundas Town League
Preston Town League
Peterborough Senior League**

CONTENTS

OBA OFFICIALS 2010		5
1.01	Name	6
1.02	Objects	6
1.03	Membership	6
1.04	Eligibility	6
1.05	Officers And Board Of Directors	6
1.06	Duties Of Officers	7
1.07	Meetings	8
1.08	Amendments	8
1.09	General	9
1.10	Appeal Procedure	9
FESS AND CERTIFICATE TAXES		10
2.01	Membership	10
2.02	Fees	10
2.03	Certificate Tax	10
2.04	Classification	10
3.01 TERRITORIAL RIGHTS		12
CHAMPIONSHIPS		12
4.01	Dates On Which Association Championships Must Be Declared	12
4.02	Visiting Team Responsible For Expenses	12
4.03	OBA Play-Off Tournament Fee	12
5.01 SPECIAL PLAYING RULES		12
5.01	Rules	12
5.02	Baseballs	13
6.01 CONVENORS		13
FINANCIAL NOTES		13
7.01	Financial Claims	13
7.02	Appeal Of Fines	13
8.01 SUSPENSIONS		13
10.01 CHAMPIONSHIP AWARDS		14
GENERAL		14
11.01	General	14
11.02	Insurance	14
P1 PLAYER SIGNING		15
Section P1.1	AGE AND CATEGORY	15
Section P1.2	BIRTH CERTIFICATES	15
Section P1.3	PLAYERS TO QUALIFY UNDER RESIDENCE RULE	15
Section P1.4	PLAYERS CHANGING TEAMS OR RESIDENCE	16
Section P1.5	PLAYERS MAY ADVANCE TO HIGHER SERIES	17
Section P1.6	PLAYER REGISTRATION	18
Section P1.7	TEAM NUMBER	19
Section P1.8	PROFESSIONAL PLAYERS AND REINSTATEMENT	19
Section P1.9	ELIGIBILITY	19
Section P1.10	PBLO	19
P2 SPECIAL PLAYING RULES		20
Section P2.1	REPORTING ABUSE	20
Section P2.2	GIRLS BASEBALL	20

Section P2.3	PROHIBITION ON THE USE OF TOBACCO PRODUCTS, ALCOHOL AND DRUGS	20	
Section P2.4	COACHES AND MANAGERS	20	
Section P2.5	UNIFORMS/EQUIPMENT	20	
Section P2.6	APPROVED BASEBALLS	21	
Section P2.7	GAME LENGTH	21	
Section P2.8	LINE-UP RULES	22	
Section P2.9	SUBSTITUTIONS	22	
Section P2.10	PITCHING RULES	22	
Section P2.11	BASE RUNNING RULES	23	
Section P2.12	FIELDING RULES	23	
Section P2.13	EJECTIONS	24	
Section P2.14	PROTESTS	24	
P3	UMPIRES		24
Section P3.1	GENERAL	24	
Section P3.2	FEES FOR UMPIRES	25	
P4	FIELD DIMENSIONS		26
P5	OBA PLAY-OFF PROCEDURES		29
Section P5.1	FORMAT FOR OBA PLAY-OFF TOURNAMENTS	30	
P6	OBA ELIMINATION TOURNAMENT PROCEDURES		50
P7	EXHIBITION GAMES AND TOURNAMENTS		51
Section P7.1	PLAYING NON-REGISTERED TEAMS AND PLAYERS	51	
Section P7.2	EXHIBITION GAMES AND OUT OF PROVINCE PLAY	51	
Section P7.3	OPEN, INVITATIONAL AND INTERNATIONAL TOURNAMENT PROCEDURES	51	
Q1	APPROVED PLAYING RULES OF T-BALL		52
Section Q1.1	GENERAL	52	
Section Q1.2	EQUIPMENT	53	
Section Q1.3	DEFINITIONS	53	
Section Q1.4	GENERAL RULES	54	
Section Q1.5	PLAYING RULES	55	
Section Q1.6	UMPIRES	56	
Q2	THE APPROVED PLAYING RULES OF ROOKIE BALL		57
Section Q2.1	REGULATIONS	57	
Section Q2.2	DIAMOND LAYOUT	57	
Section Q2.3	PLAYING RULES	57	
Section Q2.4	APPROVED BALLS FOR ROOKIE BALL	58	
	APPENDIX “A”		59
	APPENDIX “B”		60

ONTARIO BASEBALL ASSOCIATION, INC.
131 Sheldon Drive, Unit 3, Cambridge, ON, N1R 6S2
Tel: 519-740-3900 Fax: 519-740-6311
E-mail: baseball@baseballontario.com www.baseballontario.com

OBA OFFICIALS 2010

President:	Mark Orton	905-725-2145	morton0306@rogers.com
First Vice President:	David Huctwith	905-891-6117	david.huctwith@sympatico.ca
Second Vice President:	Dirk Drieberg	905-832-6520	Double.d@rogers.com
Immediate Past President:	Don McKnight	905-833-5353	donmck@bellnet.ca
Elected Board:	Jeffrey Albaum	905-773-1045	jalbaum@rogers.com
	Allan Ebert	519-542-5861	ebert@mnsi.net
	Bob Humphries	519-455-0383	Robert.humphries@sympatico.ca
	Tony Jasinski	905-278-2066	tjjasinski@rogers.com
	Stan Pagonis	905-884-0060	stanpagonis@rogers.com
	Bobbi Reive	519-733-3200	spbanews@yahoo.ca
	Howie Birnie	416-485-1848	hwbirnie@rogers.com
OBA Registrar:			
Treasurer/Supervisor of Umpires:	Ed Quinlan	416-805-6661	ed.quinlan@hrblock.ca
Director of Coach & Player Development:	John Milton	905-857-7231	jctjmilton@sympatico.ca
Life Members:	Jim Lutton	905-725-4888	jelutton@sympatico.ca
	Keith Weese	519-862-1077	
Honorary Members:	Ron Pegg	519-924-3538	crpegg@bmts.com
	Lee Nantais	519-969-1448	madlee@mnsi.net
	Vi Christopher	613-967-4958	christopher.vi@sympatico.ca
	Dennis Ryan	905-575-7677	dennis.ryan022@sympatico.ca
	Bernie Soulliere	519-735-2028	berniebaseball@canoemail.com
	Howie Birnie	416-485-1848	hwbirnie@rogers.com
	Linda Lewis	519-892-1127	lewislajc@aol.com
Previous Presidents:	Gerry MacLean	905-227-1389	
	Peter Topolie	705-497-3540	petertopolie@hotmail.com
	Randy Pickle	905-723-1527	emailforrandy@rogers.com
Competition Committee Chair:	Dirk Drieberg	905-832-6520	Double.d@rogers.com
Technical Committee Chair:	Allan Ebert	519-542-5861	ebert@mnsi.net
Tournament Chair:	Dirk Drieberg	905-832-6520	Double.d@rogers.com
Overall Series Chair:	Dirk Drieberg	905-832-6520	Double.d@rogers.com
Senior Chair:	Don McKnight	905-833-5353	donmck@bellnet.ca
Junior Chair:	Howie Birnie	416-485-1848	hwbirnie@rogers.com
Midget Chair:	Allan Ebert	519-542-5861	ebert@mnsi.net
Bantam Chair:	Jeffrey Albaum	905-773-1045	jalbaum@rogers.com
Peewee Chair:	Bobbi Reive	519-733-3200	spbanews@yahoo.ca
Mosquito Chair:	Tony Jasinski	905-278-2066	tjjasinski@rogers.com
Rookie Ball Chair:	Bob Humphries	519-455-0383	robert.humphries@sympatico.ca
Girls/Women's Chair:	Jeffrey Albaum	905-773-1045	jalbaum@rogers.com

**CONSTITUTION
of the
ONTARIO BASEBALL ASSOCIATION**

1.01 NAME

The name of this organization shall be the "Ontario Baseball Association, Inc." (unless the context otherwise requires, hereinafter referred to as the "OBA"). The OBA is authorized to carry on its business under the name "Baseball Ontario".

1.02 OBJECTS

The objects of the OBA shall be in order of priority:

- a) To foster and improve baseball at all levels in the Province of Ontario.
- b) To protect and promote the mutual interests of the members.
- c) To institute and regulate competition for the Ontario championships.
- d) To institute and regulate competition for determining the Ontario representative(s) in the national or Canadian play-offs.

1.03 MEMBERSHIP

- a) Membership in the OBA shall be composed of such Affiliated Associations, Local Associations, Associate members and Direct Entries, which shall agree to abide by and comply with the OBA Constitution and By-Laws. Members of the OBA Board of Directors, both those elected and appointed, Life Members, Honourary Members and Past Presidents shall also be members of the OBA.
- b) The OBA Board of Directors shall have the power to accept individual teams where they are unable to secure grouping in any Affiliated Association. For purposes of the OBA Constitution and By-Laws, the term "Direct Entry" shall mean a team affiliating directly with the OBA and not through an Affiliated Association.
- c) The Ontario Vintage Baseball Association shall be an Associate Member of the OBA. This membership shall be subject to the terms of an agreement approved by the OBA Board of Directors.
- d) Select Ontario Baseball Association shall be an Associate Member of the OBA. This membership shall be subject to the terms of an agreement approved by the OBA Board of Directors.
- e) Premier Baseball League of Ontario ("PBLO") shall be an Associate Member of the OBA. This membership shall be subject to the terms of an agreement approved by the OBA Board of Directors (the "PBLO Agreement").

Note: A baseball association, which is a direct member of the OBA, will be known as an "Affiliated Association" and a baseball association, which is a direct member of an Affiliated Association, and an indirect member of the OBA, shall be known as a "Local Association".

1.04 ELIGIBILITY

- a) Teams Eligible: To be eligible for OBA Play-offs, teams must represent a municipality, or a portion thereof, within the boundaries of the Province of Ontario and must be made up of players who qualify under the residence rule.
- b) Players Eligible: To be eligible, all players must qualify under the residence rule. Former professional baseball players who have been re-instated by the OBA in accordance with Rule P1-8 and athletes who are classified as professionals in other sports are eligible.

1.05 OFFICERS AND BOARD OF DIRECTORS

- a) i) 1) Management of the OBA shall be handled by the OBA Management Board. The members of the Management Board shall be the President, 1st Vice President, 2nd Vice President, Immediate Past President, 6 elected Directors and the Treasurer. The President, 1st Vice President and 2nd Vice President shall be elected annually for a maximum of 3 successive terms. The 6 elected Directors shall be elected annually. In addition, the 4 additional members of the OBA Board of Directors appointed by the President pursuant to paragraph a) (i) 2) below, shall be members of the OBA Management Board.
- 2) The operations of the OBA shall be handled by the OBA Board of Directors. The members of the OBA Board of Directors shall be the President, first Vice President, second Vice President, the Immediate Past President, 6 elected Directors, the Treasurer, all Life Members, Honourary Members, Past Presidents and 1 appointed Director from each Affiliated Association to be appointed by that Affiliated Association. In addition, the President may, subject to ratification by the OBA Board of Directors, appoint 4 additional Directors to the OBA Board of Directors.
- ii) Each member of the OBA Management Board shall have 1 vote at all meetings of the OBA Management Board. Each member (elected or appointed, including Life Members and the Immediate Past President) of the OBA Board of Directors shall have 1 vote at each meeting of the OBA Board of Directors.
- iii) Annually, a Treasurer shall be appointed by the OBA Board of Directors; his/her term to run from December 1st to November 30th of the following year, and he/she shall be paid a specified honorarium.
- iv) A Finance Committee may be appointed by the OBA Management Board to assist in the preparation of budgetary statements.
- v) An Executive Director and an Administrator may be hired by the OBA Management Board, subject to ratification by the OBA Board of Directors. The Executive Director's duties shall be as directed by the OBA Management Board. The Administrator shall act as the Secretary of the OBA in addition to any other duties delegated by the OBA Management Board.

- b) The OBA Board of Directors shall have control of the affairs of the OBA and shall have power to fill vacancies which may occur in its number subject to the provisions for appointments to the OBA Board of Directors as already laid down in paragraph a) (i) 2) and to amend or alter the regulations of the OBA Play-off competitions, to issue or revoke rosters of teams and to deal with such cases, and shall appoint Convenors in different sections throughout the province to assist in OBA Play-offs, organization, etc. The OBA Board of Directors shall also have the power to deal with cases which are not otherwise provided for or covered by the OBA Constitution and By-Laws.
- c) The President may appoint, from time to time, 1 or more committees of the Board of Directors as required to consider such matters as may be dealt with by the OBA Board of Directors and generally act on behalf of the OBA Board of Directors between meetings of the OBA Board of Directors. Such committee(s) shall be comprised of 1 or more members of the OBA Board of Directors as the President may deem fit. Decisions of such committee(s) (other than with respect to a protested game pursuant to P2-7) may be appealed to the OBA Board of Directors at its next meeting.
- d) The OBA Board of Directors shall meet once a month during the season when business warrants. 7 members shall form a quorum for meetings of the OBA Board of Directors.
- e) Any member of the OBA Board of Directors (excluding Life Members, Honorary Members and Past Presidents) who fails to attend 3 consecutive meetings, without reasons that in the opinion of the OBA Board of Directors are satisfactory, shall have automatically tendered his/her resignation. After 2 consecutive misses, this detail shall be brought to his/her attention by a letter from the OBA Office. Should the third consecutive miss occur, except for a member appointed by an Affiliated Association, the OBA Board of Directors will appoint a replacement. If the member was an appointee from an Affiliated Association, that Affiliated Association shall be requested to appoint the replacement and must notify the OBA Office of such appointment within 3 weeks.
- f) The position of Life Member can only be conferred on an individual upon the recommendation of the OBA Board of Directors after 15 years or more of continuous faithful service by the individual to the OBA and where a definite desire exists to retain the active service of the individual with an official status. To be appointed a Life Member, the individual must have previously been appointed an Honourary Member. The total number of Life Members that the OBA may have at any one time shall not exceed 3, but terms of Life Memberships conferred prior to 1972 will continue to their expiration.
- g) The position of Honourary Member may be conferred by the OBA Board of Directors for outstanding continuous and meritorious service to the OBA. Future Life Members are to be selected from Honourary Members. Honourary Members shall have the right of delegates at all Annual Meetings and Special Meetings of the OBA, including the right to vote.
- h) Nominations for Officers:
Officers shall be nominated (in writing) by an Affiliated Association in good standing and operating the previous year, or by a member of the OBA Board of Directors. The nominations must be at the OBA Office not later than October first prior to the date of the Annual Meeting. In order for a name to remain on the ballot, a nominee must so request at the Annual Meeting in person, or must have indicated to the OBA Office in writing, prior to the election.
- i) Past Presidents:
Past Presidents shall have the right of delegates at all Annual Meetings and Special Meetings of the OBA, including the right to vote.
- j) Any member of the OBA Management Board may be removed from office for conduct detrimental to the OBA at a meeting of the OBA Board of Directors upon a resolution approved by 3/4 of the votes cast in respect of such resolution. Notice must be given at least 7 calendar days prior to the meeting to all members of the OBA Board of Directors of the intention to bring such a resolution before the meeting.

1.06 DUTIES OF OFFICERS

- a) It shall be the duty of the President to preside at meetings of the OBA Management Board and OBA Board of Directors. The President shall also perform such other duties as are necessary for the proper conduct of the office of President.
- b) The first Vice President, in the absence of the President, shall have all the powers and perform all the duties of the President. The first Vice President shall also perform such duties as may be assigned to him/her by the President.
- c) The second Vice President, in the absence of the first Vice President, shall have all the powers and perform the duties of the first Vice President. The second Vice President shall also perform such duties as may be assigned to him/her by the President.
- d) The 6 Elected Directors shall perform such duties as may be assigned to them by the President.
- e) The Immediate Past President shall perform such duties as may be assigned to him/her by the President and shall offer such advice and guidance to the OBA Management Board and OBA Board of Directors as may be requested.
- f) The President shall annually appoint an individual who will act as the OBA Registrar. The appointee shall be responsible for approving all team rosters, reinstatements, and the registration of all birth certificates. The OBA Registrar shall work in conjunction with the Administrator in the processing of the related documents.
- g) All cheques issued by the OBA must be signed by the Treasurer and the President (or any other member of the OBA Board of Directors approved by the OBA Management Board in the absence of the President). The signatures of any such authorized signatory shall be cleared at the bank immediately following their taking office or their being so authorized by the OBA Management Board. All vouchers must be presented at the OBA Management Board Meetings for approval of payment.
- h) The Administrator shall keep an accurate record of the proceedings of the OBA, including OBA Management Board and OBA Board of Directors meetings and a register of all Affiliated Associations.
- i) The Treasurer shall keep an accurate record of all monies received and disbursed by the OBA and report at least annually to the members of the OBA. The Treasurer's books shall be audited annually by an accredited auditor.
- j) All appointed members of the Board of Directors shall perform such duties as may be assigned to them by the President.

1.07 MEETINGS

- a) The Annual Meeting of the OBA (which term shall include an Annual and Special Meeting) shall be held on the third Saturday and Sunday in November. The sites for future Annual Meetings shall be determined by the OBA Management Board. When determined, the sites for future Annual Meetings shall be announced at the Annual Meeting.
- b) No delegate shall be permitted to speak or vote at an Annual Meeting or Special Meeting unless he/she has filed with the Secretary, a certificate of his/her appointment, signed by the Secretary of the Affiliated Association or Direct Entry which he/she represents.
- c) Annual member's fees for the then current period October 1st to September 30th must be paid by an Affiliated Association or Direct Entry before that Affiliated Association's or Direct Entry's delegate(s) shall have a voice or vote at Annual Meetings or Special Meetings of the OBA.
- d) "Special Meetings" - The President may call a special general meeting of the OBA ("Special Meeting") at any time, but must do so at the request of 3 Affiliated Associations. At all Special Meetings, 8 delegates shall form a quorum. 4 days notice of such meeting must be given and the reason for such meeting.
- e) Affiliated Associations must operate the previous year under the jurisdiction of the OBA before having the right of voice at an Annual Meeting or Special Meeting of the OBA.
- f) At an Annual Meeting or Special Meeting of the OBA, each Affiliated Association shall be entitled to the following votes:
 - Affiliated Associations with more than 24 teams..... 4 VOTES
 - Affiliated Associations with from 5 to 24 teams 2 VOTES
 - Affiliated Associations with less than 5 teams 1 VOTE.
- g) No delegate from an Affiliated Association in arrears to the OBA in any way, shall be permitted to vote at an Annual Meeting providing notice of such arrears has been given in writing to the Affiliated Association a month prior to the Annual Meeting.
- h) "Electing Officers and Directors" - The OBA shall, at its Annual Meeting, provide the delegates with a proper form of printed ballot, giving the offices and nominations for each. In the case of the nominations for elected Directors, of which 6 are to be elected annually, all voting delegates must mark their ballots for 1, 2, 3, 4, 5 or 6 of the candidates nominated and where such is not done, the ballot is to be considered spoiled and not counted.
- i) A delegate may only vote as a representative of the Affiliated Association through which he/she is registered or in whose territory he/she resides.
- j) At an Annual Meeting or Special Meeting of the OBA, each Associate Member shall be entitled to the following votes:
 - i) with respect to amendments to Articles 1 to 10 inclusive, of this Constitution (including amendments or other procedural matters relating to such amendments), 1 vote;
 - ii) with respect to the election of Officers or Directors of the OBA 1 vote; and
 - iii) with respect to all other matters, zero votes.In the case of an Associate Member which, at the time this section j) comes into force and effect, has an agreement approved by the OBA Board of Directors providing for different rights, such Associate Member shall have such rights as are set out in such agreement for the term of such agreement. The OBA Board of Directors shall not renew any such agreement on terms which would violate this section j). If any such agreement is for an indefinite term, the OBA Board of Directors shall use their best efforts to seek an amendment of such agreement in order that it not be in breach of this section j). Any Affiliated Association shall have the right to request a copy of any such agreement.

1.08 AMENDMENTS

- a)
 - i) An amendment to the OBA Constitution and By-Laws may only be made at an Annual Meeting and must be approved by 2/3 of the votes cast in respect of such amendments in order to carry. Notice of any proposed amendment must be filed with the OBA Office in writing by October first prior to the Annual Meeting and the OBA Office shall then forward by mail a copy to each Affiliated Association no later than November first, before the Annual Meeting. Amendments passed and carried shall become effective at the conclusion of the Annual Meeting at which they are passed.
 - ii) An amendment may only be proposed by the OBA Board of Directors or by an Affiliated Association in good standing.
- b) At an Annual Meeting, the OBA Board of Directors may propose a resolution for an experiment that differs from the OBA Constitution and By-Laws. This experiment may be put into effect as an experiment for no more than 2 years. In order to be adopted, the resolution must be approved by 2/3 of the votes cast in respect of the resolution and would be subject to annual review by the OBA Board of Directors. Any references in the Constitution that are contrary to the experiment are suspended while the experiment is in progress. Once the time period for the experiment has expired, unless an amendment to the OBA Constitution and By-Laws is adopted with respect to the subject matter of the experiment, the resolution shall be of no further force and effect and the suspension of any references in the OBA Constitution and By-Laws shall be removed.
- c) Order of Business - Annual Meeting:
 - ii) President's Address.
 - iii) Reading of the Minutes of the last Annual Meeting and any Special Meeting during the year.
 - iv) Administrator/Secretary's Report.
 - v) Treasurer's Report.
 - vi) Auditor's Report.
 - vii) Correspondence.
 - viii) Host's Comments and Address.

- ix) Reports of Board Committees.
 - x) Consideration of Reports.
 - xi) Amendments - Notice of Motion.
 - xii) General Business.
 - xiii) Election of Officers and Directors.
 - xiv) Annual Meeting - Site for the following year.
- d) Rules of Order of Annual Meeting or Special Meeting:
The following are the regulations of the government of the OBA during the time of business, and the business shall be disposed of in the following order:
- i) No motion shall be received unless properly moved and seconded. Said motion shall not be open for discussion until so stated by the presiding officer.
 - ii) Except for motions requiring a special majority either pursuant to the OBA Constitution and By-Laws or at law, all motions shall be decided by a majority of votes cast. When the presiding officer sees fit to exercise his/her right to vote on any question before the meeting, he/she shall, from the chair, be at liberty to explain his/her vote, and any question on which there is an equality of votes in consequence of the presiding officer's vote, shall be deemed to be negative.
 - iii) No delegate shall speak twice on the same motion without the permission of the chair, unless in explanation, or the mover in reply.
 - iv) A delegate desiring to speak or submit a motion shall rise and remain standing until recognized by the chair. In speaking, a delegate shall respectfully address the chair and shall confine his/her remarks to the motion under debate. The delegate shall not be interrupted unless upon a point of order. Non-delegates may be permitted to speak at the discretion of the chair.
 - v) No amendment to a motion shall be in order after an amendment to the amendment.
 - vi) When a motion is under debate, no motion shall be entertained except to lay on the table or amend and these motions shall take precedence in the order named.
 - vii) An amendment, which entirely changes the subject of the original motion, shall not be entertained as an amendment or substituted for the motion under debate.
 - viii) After the motion has been stated by the presiding officer it becomes the property of the OBA but may be withdrawn at any time prior to amendment, unless objected to by a delegate.
 - ix) There shall be no debate upon any question after it has been put by the presiding officer.
 - x) When a vote is called, it shall be taken by each delegate holding up his/her right hand. The presiding officer shall declare the vote on all questions and should his/her declaration be disputed, he/she may require the delegates voting "Yea" and "Nay" to rise and stand until the number voting for the affirmative and the negative be counted by him/her.

1.09 GENERAL

- a) The OBA Constitution and By-Laws as shown in this book are intended as a general guide and cannot specifically cover each situation that may arise. Therefore, the President in regular or special meetings, with a quorum of the OBA Board of Directors, will have the authority to interpret and decide to the best of their judgement with regard to all the circumstances or any specific case, any matter pertaining to any and all clauses contained herein. Their decision shall be final. The OBA Management Board or the OBA Board of Directors shall appoint an Advisory Committee comprised of the Past Presidents and Life Members to advise upon matters presented to them by the officers, OBA Management Board or OBA Board of Directors.
- b) Any Affiliated Association and/or officers of same, which fails to uphold the rulings and enforce the decisions of the OBA will leave said Affiliated Association, and/or officers open to suspension by the OBA.
- c) A catalogue of OBA approved forms for requesting and/or recording of information to be submitted to the OBA Office be included as an Appendix in the Constitution. Forms will be reviewed and updated annually.

1.10 APPEAL PROCEDURE

- a) Any decisions made by the OBA (other than a protested game, which is governed by P2-14 and classifications which are governed by 2.04 e) may be appealed to the President, in writing, with a deposit of \$100.00. The appeal must be made within 14 days of the decision being appealed.
- b) When the President receives an appeal in writing, the President shall review the appeal and determine whether, in the President's discretion, the appeal either (i) presents new information not available or presented to the board or committee which made the decision appealed from or (ii) represents an important and compelling matter which justifies the holding of an appeal. Where the President determines that either (i) or (ii) applies, the President shall name a committee of at least 3 members of the OBA Board of Directors who shall hear the appeal. The decision of the committee shall be final. The committee shall also rule on the disposition of the deposit.
- c) The President shall establish the time and place of the appeal hearing. The hearing must be held within 30 days of receiving the written appeal. The 30 days shall begin the day following the receipt of the written appeal.
- d) The appellant must be present in person at the hearing. Failure to appear will result in a default decision and no further appeal shall be allowed.

FESS AND CERTIFICATE TAXES

2.01 MEMBERSHIP

- a) Every Affiliated Association desirous of joining the OBA shall send to the OBA Office a completed application for membership, a list of its officers, a copy of its constitution and by-laws.
- b) All teams of Local Associations of any classification desirous of entering the OBA Play-offs must affiliate through an Affiliated Association in their area or directly with the OBA where there is no Affiliated Association in their area.
- c) Teams of Local Associations must register with the OBA through the Affiliated Association in which territory they play their home games ("Home Affiliate"). Teams may be released to participate in a league schedule of another Affiliated Association ("League Affiliate"), but will be registered with and classified by the Home Affiliate. Released teams and their players will be subject to the rules and regulations of the League Affiliate. Released teams will be subject to the player release rules as set out by the Home Affiliate. Team releases must be in writing and there will be no charge for the release of any such team.

2.02 FEES

- a) The annual member's fee shall be:
 - For each Affiliated Association which operates 50 or more teams\$125.00
 - For each Affiliated Association which operates up to 49 teams\$100.00
 - Direct Entries - each team T-Ball, Rookie Ball to Senior\$40.00

Note: Such fees are due and payable by September 30 of each fiscal year.
- b) Each Direct Entry must pay a guarantee deposit of \$500.00 to be returned only if the Direct Entry completes its obligations as stated in the OBA Constitution and By-Laws.

2.03 CERTIFICATE TAX

- a) A team certificate tax of \$75.00 will be paid by each Affiliated Association or Direct Entry, as the case may be, to the OBA for each of its teams.
- b) The certificate tax must be paid by July 8th to the OBA Office. Failure to pay the certificate tax shall result in the applicable team(s) not being classified.

2.04 CLASSIFICATION

- a) The OBA shall offer for annual competition the following OBA Play-offs:

Category	25,000+ Households	Under 25,000 Households
Senior Rookie Ball	AAA, AA, A	B, C, D
Minor Mosquito	AAA, AA, A	B
Mosquito	AAA, AA, A	B, C, D
Peewee Girls	AAA	
Minor Peewee	AAA, AA, A	B
Peewee	AAA, AA, A	B, C, D
Bantam Girls	AAA	
Minor Bantam	AAA, AA, A	B
Bantam	AAA, AA, A	B, C, D
Minor Midget	AAA, AA	
Midget	AAA, AA, A	B, C, D
Category	All Households	
Women	AAA	
Junior	A, B, C	
Senior	A, B, C, D	

In addition, OBA shall offer the following championships through PBLO:

AAAA Midget
AAAA Minor Midget

- b) Household numbers are used only to determine categories teams are eligible to participate in. Teams may request higher classification if so desired. A team at a lower household category may be classified at the classification of a larger household category at its request.
- c) For purposes of classification, the number of households will be based on Canada Post data published in January of each year.
- d) Teams signing players outside of their recognized boundaries shall absorb the households of such players for classification purposes."

- e) If any Local Association feels it has a circumstance that does not fall under the provisions of 2.04 a) to d), it has the right to appeal to the O.B.A.
- f) Classifications must be submitted to the OBA Office before the opening of business on the Tuesday immediately following the 2nd Monday of July. Failure to submit such information by the deadline shall result in the applicable team(s) not being classified.
- g) The OBA Office shall immediately forward the Affiliated Associations' proposed classifications to the respective Series Chair, who shall be responsible for ensuring that all information provided for each team in the Series is complete and correct. The Series Chair shall ensure that each team is properly classified and review the potential number of entries in the individual classification playoffs.
- h) The Series Chair shall make final recommendations as to team classifications. If the Series Chair moves a team, the Local Association and the Affiliated Association shall be contacted and advised of the change and the reasoning for the change. The Local Association and/or the Affiliated Association shall have until the close of business on the Friday immediately following the 3rd Monday of July to appeal the change to the Series Chair. The classification recommended by the Affiliated Association may be changed by the Series Chair based on the performance of the team, the quality of its competition, and the size of the community.
- i) The Affiliated Association must submit with classification the maximum number of teams it will allow to participate in each category.
- j) The Classification Committee shall consist of the Overall Series Chair and the Series Chair. The Classification Committee shall meet no later than one week prior to the Civic Holiday weekend to review the recommendations of the Series Chair. The Classification Committee shall also resolve any appeals, to classifications, that are outstanding. The Classification Committee shall present its final recommendations to the Competition Committee no later than one week prior to the Civic Holiday.
- k) The decision of any Affiliated Association with respect to whether a team is, or is not classified, prior to the opening of discussions by the Classification Committee on the classification of all teams in the respective series, shall be deemed final by the OBA.
- l) Where required for classification purposes, the Affiliated Association must submit to the Classification Committee (on a form approved by the OBA) the schedule and results of the teams in any league play, the won-lost-tied record and any tournament results that the teams may have participated in. Failure to comply with these rules will result in the team being classified at the highest classification available under 2.04 a).
- m)
 - i) Except for OBA Play-offs for Rookie Ball, Girls Baseball and Senior, the number of teams allowed to participate at each classification shall be one per Affiliated Association plus the tournament host. In any series where the number of Affiliated Associations participating plus the tournament host is less than 12, the number of teams which will be allowed to participate would be up to 12 including the tournament host. The OBA Board of Directors shall determine the manner of selection of the additional teams to make up the 12 team tournament. If there are less than 12 teams classified at a classification, all teams will be permitted to participate.
 - ii) At Rookie Ball, Girls Baseball and Senior, each OBA Play-off Tournament shall be open to all teams classified at the category. All teams are eligible to participate, but must fill out the appropriate application. Deadline for entry to these tournaments shall be July 31. Tournaments in excess of 20 teams may require playdowns one week prior to the OBA Play-off Tournament being played.
- o) The OBA Board of Directors shall decide annually the method by which the winner of each OBA Play-off shall be declared. This method shall consist of one of the following:
 - i) home and home style OBA playoffs; or
 - ii) a double loss knock-out tournament with a minimum of 6 teams scheduled to be held no later than the Labour Day weekend; or
 - iii) a round robin tournament; or
 - iv) a combination.
- p) No player may participate with more than 1 team in any 1 series.
- q) Any team classified at the OBA classification meeting must participate in all its OBA Play-offs. If a team fails to fulfil its commitment a \$500.00 fine will be assessed. Local Associations and Affiliated Associations shall be responsible for ensuring payment of such fines assessed against their teams.
- r) Teams appealing their OBA classification as finalized by the OBA Board of Directors are not to be levied the OBA \$500.00 fine if the team declines to compete within 24 hours after the appeals meeting.
- s) The winner of the Senior OBA Elimination Tournament will be declared the OBA Senior A champions.
- t) A Direct Entry not participating in the scheduled play of an Affiliated Association shall be classified at the highest level for which the households of its municipality makes it eligible.
- u) In order to be classified, a team must have played and reported on the Classification Form a minimum of 5 games against other OBA rostered teams.
- v) The winner of the Junior OBA Elimination Tournament will be declared OBA Junior A champions. In years when there is no Junior OBA Elimination Tournament, an open tournament will be held on the Civic Holiday weekend with the winner being declared OBA Junior A champion.
- w) At each age category where the winner of the OBA Elimination Tournament is not deemed an OBA Play-off Champion, the winner of the OBA Elimination Tournament shall be granted an automatic entry into the OBA Play-off Tournament for which teams entering the OBA Elimination Tournament are classified. The OBA Elimination Tournament winners will not be considered the representative of the Affiliated Association to which it belongs and the Affiliated Association shall be entitled to send another of its teams as its representative. OBA Elimination Tournament winners must declare their intentions to the OBA Office and the OBA Play-off Tournament host by August 15.
- x) For Rookie Ball and Girls Baseball, the OBA Play-off Tournament format shall be at the discretion of the OBA Board of Directors each year.

- y) Where several municipalities or Local Associations of C or lower classifications desire to compete in open tournaments at the AA and AAA level, they may choose to register an Affiliated Association approved team for that purpose. Such teams shall not be eligible for OBA Play-offs and OBA Elimination Tournaments, and players on such a team are obliged to honour commitments to their Local Association first.

3.01 TERRITORIAL RIGHTS

- a) The status of all Affiliated Associations is defined as territorial rights, as set forth in Appendix C. The boundaries of each have been approved and set by the OBA. Any new baseball associations, which do not conflict with any established Affiliated Association, which desire to affiliate with the OBA, must first be approved by the OBA Board of Directors.
- b) All applications by Direct Entries for direct entry must be approved by the OBA Board of Directors before being accepted.
- c) The OBA Board of Directors shall have the power to mediate boundary disputes and make changes to Affiliated Association boundaries where such changes are deemed to be in the best interests of baseball.
- d) Franchises in the PBLO shall declare themselves to operate as either Residency Franchises or Non-Residency Franchises. A Residency Franchise is one that determines to operate in accordance with OBA's residence and release requirements. A Residency Franchise will have the territorial rights of the Local Association, Direct Entry or Affiliated Association which is operating the Franchise. A Non-Residency Franchise is one that determines not to operate in accordance with OBA's residence and release requirements. A Non-Residency Franchise shall have no territorial rights.

CHAMPIONSHIPS

4.01 DATES ON WHICH ASSOCIATION CHAMPIONSHIPS MUST BE DECLARED

- a) Each Affiliated Association in order to participate in the OBA Play-offs must be prepared to enter the OBA Play-offs on the dates as set by the OBA Board of Directors (for all series) but in no case shall that date be later than the fourth Saturday in August.
Note: Labour Day weekend (except in Junior, Midget and Girl's Baseball) is the recommended dates for Tournament style OBA Playoffs.
- b) No OBA Play-off may be ordered after October 5th. The Series Chair has the power to order a tournament to be held to declare a winner, if deemed necessary.
- c) Where exceptional circumstances arise in Affiliated Associations, only the OBA Board of Directors or its committee(s) are empowered to extend the date of declaring a winner. The request for extension must be at the OBA Office at least 2 weeks prior to the OBA Play-off date.
- d) Except at Junior A which will be the Junior OBA Elimination Tournament or as provided for in 2.04 v), all Junior OBA Play-offs will be scheduled 2 weeks prior to Labour Day weekend.
- e) Girls Baseball OBA Play-offs will be scheduled at least 1 week but not more than 2 weeks prior to Labour Day weekend.
- f) All Midget OBA Play-offs will be scheduled 1 week prior to Labour Day week-end.
- g) Except at Senior A which will be the Senior OBA Elimination Tournament, all Senior OBA Play-offs will be scheduled 1 week prior to the Labour Day week-end. [NOTE: This provision is suspended for 2010. In 2010, Senior A will be the Senior OBA Elimination Tournament. Senior B, C and D will be on Labour Day Weekend.]

4.02 VISITING TEAM RESPONSIBLE FOR EXPENSES

The visiting teams shall pay their own travelling expense.

4.03 OBA PLAY-OFF TOURNAMENT FEE

All teams in OBA Play-off Tournament play will pay the following participation fees to the tournament host:

- a) teams in PeeWee and below.....\$350.00
and
- b) teams in Minor Bantam and above.....\$400.00.

If the team defaults on the payment of such fee or fails to meet its commitment to play in the OBA Play-off tournament, the OBA will pay the appropriate tournament fee to the host, pending any appeals. The OBA will collect the fine from the offending Affiliated Association/Local Association.

5.01 SPECIAL PLAYING RULES

5.01 RULES

- a) The OBA Board of Directors shall create a Special Playing Rules Committee and appoint a Chair Person for this committee.
- b) The Special Playing Rules Committee shall be made up of the Chair Person appointed by the OBA Board of Directors, and a representative from each Affiliated Association. In addition, the committee shall also have a member from the Technical Committee, a member from the Competition Committee, a member of the Umpire Committee and a member of the Coaching Committee. Each of these members shall act in an advisory capacity and shall not have a vote.

- c) Each Affiliated Association shall have one vote and a simple majority in attendance is required to pass any changes. The Special Playing Rules Committee may entertain and discuss rule changes throughout the year. Any changes shall be submitted to the OBA Board of Directors at the meeting prior to the meeting at which the changes will be considered by the OBA Board of Directors. The Special Playing Rules Committee shall meet no later than the last Sunday in September to review and vote on the proposed changes for the coming season.
- d) The Special Playing Rules Committee shall prepare a report to the OBA Board of Directors on the proposed changes to be presented at the October meeting prior to the OBA Annual Meeting. The OBA Board of Directors will approve changes recommended by the Special Playing Rules Committee. Changes must be approved by 2/3 of the votes cast in respect of such changes in order to carry.
- e) The Special Playing Rules Committee shall send the approved changes to each of the Affiliated Associations and present a workshop at the Annual Meeting and the Best Ever Clinic to communicate the changes.
- f) The Special Playing Rules Committee shall publish each year the special playing rules for the coming season.
- g) Such rules may include fines and ejections to be imposed against teams, Local Associations and/or Affiliated Associations for failure to comply with the rules."
- h) For the purposes of this rule, the special playing rules shall include P2, P5, P6, P7, Q1, Q2 and Q3.
- i) Notwithstanding clauses a) through h), the OBA Board of Directors may from time to time review and modify Rules P2.1 through P2.5, where in the opinion of the OBA Board of Directors, the changes are in the best interests of the members as a whole and/or in matters that are related to risk management for OBA. These changes must be presented and tabled at an OBA Board of Directors meeting to be voted on at the subsequent OBA Board of Directors meeting. These changes do not require approval of the Rules Committee but require:
 - i. approval of the majority of the Affiliated Association representatives present at the OBA Board of Directors Meeting, and
 - ii. 2/3 of votes cast for passage by the OBA Board of Directors.

5.02 BASEBALLS

Each year at the Annual Meeting, the OBA Board of Directors will submit for discussion and approval a list of baseballs for use in the upcoming season.

6.01 CONVENORS

- a) Affiliated Associations are to recommend OBA Convenors for approval by the OBA Board of Directors. The OBA Board of Directors will reserve the right to appoint OBA Convenors for districts where Direct Entries participate in the OBA.
- b) In any OBA Play-off game, no playing member of any team involved in the series will be allowed to act as a convenor or umpire.
- c) Only a registered OBA Convenor will act as the convenor at OBA Play-off games.
- d) In the case of the absence of an OBA Convenor, the umpire-in-chief shall act as the convenor in order for the game to begin.
- e) At the request of Affiliated Associations, the OBA will hold regional meetings to instruct OBA Convenors on proper procedures for running OBA Play-offs.

FINANCIAL NOTES

7.01 FINANCIAL CLAIMS

All financial claims must be submitted to the OBA Office within 3 months of expenditure.

7.02 APPEAL OF FINES

Any Direct Entry, Local Association or Affiliated Association desiring to appeal a fine imposed upon a team, a Direct Entry, a Local Association or an Affiliated Association must file a request to appeal the fine with the OBA Technical Committee within 45 days of receipt of notification of the fine. (Any fine issued by the OBA with respect to a tournament must be issued within 30 days of receipt of the Convenor's Report.) The OBA Technical Committee must hear an appeal of a fine within 45 days after the appeal is filed with the OBA Office.

8.01 SUSPENSIONS

- a) Any Affiliated Association or member of the OBA violating the OBA Constitution and By-Laws or refusing to abide by the decisions of the OBA Board of Directors or its committee(s) may be expelled or suspended.
- b) Any Associate Member violating the OBA Constitution and By-Laws or the agreement which governs their membership in OBA may be expelled or suspended. In the case of the PBLO, any PBLO Franchise violating the PBLO Agreement may be expelled or suspended.
- c) Teams, officers or players may be suspended by the OBA Management Board for knowingly:
 - i) Permitting betting or improper conduct by players or officers at OBA games.
 - ii) Offering, agreeing, conspiring or attempting to lose any OBA game or being interested in any pool or wager thereon.
 - iii) Playing with a team, Direct Entry, Local Association or Affiliated Association that has been suspended or expelled.
 - iv) Having on its list of signed players any disqualified players.

- v) Permitting officers to conduct business of Direct Entries, Local Associations or Affiliated Associations against the best interests of baseball.
- d) Any team or player which shall play under an assumed name shall be suspended from the OBA and any coach or manager knowingly permitting a player to play under an assumed name shall be suspended from the OBA, subject to appeal.
- e) Any player found guilty of playing over the age limit permitted in the series in which he/she is participating shall automatically be suspended along with the manager of the team.
- f) Any team found guilty of playing a player over the age limit permitted in the series in which he/she is participating, shall automatically be suspended along with the manager of the team.
- g) Any manager or coach using an ineligible player in an OBA Tournament or OBA Play-Offs shall be automatically suspended indefinitely. Any further penalty shall be decided by the OBA Board of Directors.
- h) Any player, coach or manager making physical contact with an umpire will be immediately suspended indefinitely, subject to appeal.

10.01 CHAMPIONSHIP AWARDS

- a) Championship teams of each OBA Play-off series shall receive a trophy representative of the OBA Challenge Trophy.
- b) The OBA will present the following numbers of awards to members of the championship team and finalist team of each classification:
 - i) Bantam and below: 18 awards
 - ii) Minor Midget and Midget: 20 awards
 - iii) Junior, Senior and Womens: 25 awards

GENERAL

11.01 GENERAL

The OBA was organized May 4, 1918 under the name “Ontario Baseball Amateur Association”. In 1938 the name was changed to “Ontario Baseball Association”. In 1982, the organization was incorporated as “Ontario Baseball Association, Inc”.

- a) Except as provided by the OBA Constitution and By-Laws, the management and control of each individual Affiliated Association shall be left entirely in the hands of the directors of such Affiliated Association and Local Association.
- b) Memberships in the OBA are the property of the OBA and cannot be bartered.
- c) Officers, members of the Board of Directors, Series Chairs and Convenors appointed by the Overall Series Chair may be financially reimbursed for out-of-pocket expenses in attending OBA Management Board, OBA Board of Directors or committee meetings, and also for appropriate out of pocket expenses (i.e.: telephone, fax, supplies, etc.) pertaining to OBA business during OBA Play-offs.

11.02 INSURANCE

- a) All teams of Local Associations, Affiliated Associations, Direct Entries and PBLO Franchises must have the liability insurance provided through the OBA. This insurance must be purchased before the teams, associations and franchises begin the new baseball season.
- b) For purposes of insurance coverage only, the OBA sanctions all usual baseball activities including games, practices, try-outs, evaluations, tournaments and executive activities conducted by its Affiliated Associations, Local Associations, Direct Entries and Associate Members and such other activities of the OBA, its Affiliated Associations, Local Associations and Direct Entries as may be approved from time to time by the OBA Management Board.

Section P1.1 AGE AND CATEGORY

To be eligible to play in a particular age category, a player must be born during the year indicated beside such category or during any subsequent year:

T-Ball	2002	
Junior Rookie Ball	2002	
Senior Rookie Ball	2001	
Minor Mosquito	2000	
Mosquito	1999	
Peewee Girls	1997	
Minor PeeWee	1998	
PeeWee	1997	
Minor Bantam	1996	
Bantam	1995	
Bantam Girls	1994	
Minor Midget	1994	
Midget	1992	
Junior	1989	
Women's	Unlimited	(Note: These years are to be automatically updated each year.)

Section P1.2 BIRTH CERTIFICATES

- a) Subject to the following, copies of birth certificates, passports or citizenship cards (“birth records”) must be sent to the OBA Office by all players 21 years of age and under not previously registered with the OBA. In the case of Affiliated Associations having their own registrar and having the approval of the OBA, it is not necessary to send in birth records to the OBA Office if such birth records are provided to the Affiliated Association’s registrar. For Affiliated Associations not having their own registrar or for Direct Entries, when sending birth records to the OBA Office, they must be listed and a copy of the list included with the birth records. Upon receipt of a birth record, it will be recorded in the OBA Office.
- b) All players 21 years of age and under must produce a birth record. Players who cannot procure a birth record may sign a team roster upon producing a statutory declaration sworn to by their parent or guardian establishing their age; the same to be accompanied by a certificate of a solicitor or notary public.
- c) No birth records or statutory declaration will be approved after the June 30th deadline.

Section P1.3 PLAYERS TO QUALIFY UNDER RESIDENCE RULE

- a) No player shall compete in any OBA Play-off games who has not been a bona fide and continuous resident of the municipality to which his/her team belongs before June first of the baseball season, except (1) a senior player who maintains Canadian Citizenship and has been a member of an OBA team for at least one year prior and continues to remain a member of the same OBA team and who for the purposes of securing employment lives and/or works out of the province of Ontario, (2) in the case of students who shall be allowed to take up residence until June 30th or players below Junior rating when a bona fide move of the family takes place before June 30th. (The term student for the purpose of this rule means any player who has resided away from his/her normal residence for the purpose of receiving an education. The intent here is to provide a student the opportunity to establish residence beyond the June first deadline. Players attending secondary school do not normally qualify under this provision.) **Note:** Individuals under senior age may be granted permission by the OBA Registrar to participate in OBA play. Cases will be dealt with on an individual basis (i.e. exchange students).
- b)
 - i) Where a Local Association has more than 1 team operating in the same series, the Local Association shall set policy and/or boundaries for such teams.
 - ii) Where a municipality has more than 1 Local Association within its boundaries, the Affiliated Association shall set policy and/or boundaries for such Local Associations.
 - iii) In areas where no team is available under the residency rule, the Affiliated Association shall set policy and/or boundaries for teams operating within the Local Associations of the Affiliated Association.
 - iv) Local Associations and Affiliated Associations must establish policy and territorial boundaries for teams and/or associations before the start of their baseball season. A copy of the policy and/or boundaries must be filed with the Affiliated Association and the OBA before the start of the baseball season.
 - v) Players must play for the Local Association or Direct Entry that holds their playing rights under these rules. Players must procure a release from the Local Association or Direct Entry that holds their playing rights should they wish to play for a team with another Local Association or Direct Entry. Affiliated Association Registrars must approve the transfer of those players who do not play with their Local Association teams but within the boundaries of the Affiliated Association. However, a player may return to

the team at his/her place of residence at the beginning of any season without a release. A player residing in an area where no Local Association or Direct Entry exists may play for a team in another Affiliated Association without a release provided such team is the team located closest to his/her place of residence. **Note:** Local Association and Affiliated Association rules take precedence for any Local Association or Affiliated Association.

Note: For purposes of this rule, minor (e.g. Minor Mosquito, Minor PeeWee, Minor Bantam and Minor Midget) is not defined as a separate series from major (e.g. Mosquito, PeeWee, Bantam and Midget). If a combined minor/major program is offered by a Local Association, players require a release to play in any other Local Association.

- vi) Players younger than Minor Bantam must play with a team within their Affiliated Association. Under special circumstances players younger than Minor Bantam may be granted releases but only upon approval of the Local Association, the Affiliated Association and the OBA. If a release is not granted by the Local Association or the Affiliated Association, an appeal may be made to the OBA for a final ruling. All releases of players younger than Minor Bantam granted by the Affiliated Association must be approved by the OBA.

Where a player who is Minor Bantam or older wishes to play for a team outside of their Affiliated Association, said player must procure a release from his/her Local Association and from the registrar of the Affiliated Association before becoming eligible to sign with his/her new team.

vii) All releases must be in writing and cannot be conditional.

- c) Only OBA rostered players are eligible to participate in Ontario Elimination Tournaments.
- d) Only players eligible to participate in Canadian championships shall be eligible to participate in the Ontario Elimination Tournament.
- e) A permit shall not be granted to a non-Canadian Import Player in any series other than Senior.
- f) Notwithstanding any other provision of this section P1-3, a female may, but is not required to, register with both a Girls Baseball team and a non-Girls Baseball team. Where the Local Association in whose territory the female lives offers both Girls Baseball and non-Girls Baseball teams, the female may register with either a Girls Baseball team or a non-Girls Baseball team in such Local Association and on the basis of such registration play on any team from such Local Association for which she is eligible to play based upon her age. Where the Local Association in whose territory the female lives does not offer Girls Baseball, the female may register for non-Girls Baseball with such Local Association and Girls Baseball with another Local Association without a release being required from the Local Association in whose territory the female lives. Except as provided for in this section, a female player requires a release in accordance with the provisions of section P1-4 in the same manner as a male player.

Section P1.4 PLAYERS CHANGING TEAMS OR RESIDENCE

- a) Once a player signs with a team from a Direct Entry or Local Association, he/she shall remain a member of that Direct Entry or Local Association until he/she is transferred in accordance with the regulations governing transfers as hereinafter set down (said player who has been a continuous resident for 2 or more years and on moving to another municipality or rural district, and wishes to continue playing with the Direct Entry or Local Association he/she last signed for, may do so and will not change the classification of the team from the Direct Entry or Local Association).

Note: The general principle stated above applies also to cities and towns which have more than 1 Local Association, and, in such cases, even though no change in residence is involved, the player is not allowed to change Local Associations until he/she has been transferred in the approved manner as herein set down.

Note: The OBA does not condone moves of convenience designed to bypass the release process.

To establish a legitimate family move Baseball Ontario, when considering the legitimacy of the family move, may have regard to a number of factors, including but not limited to the following:

1. A statement from the parent(s) outlining that they actually live at the stated address.
 2. A copy of the rental agreement or proof of home ownership.
 3. A driver's license with the stated address.
 4. The name and address of the school the player attends
 5. A separation agreement or divorce decree outlining the custody and access arrangements of the player.
 6. Canada Revenue Agency Marital Status Change form – RC 65
- b) A player wishing to change his/her Direct Entry or Local Association must first secure a written release from his/her old Direct Entry or Local Association signed by the current management of that Direct Entry or Local Association and, where that Direct Entry or Local Association is not the association in whose boundaries the player resides, the player must also secure a written release from the Direct Entry or Local Association in whose boundaries the player resides signed by the current management of that Direct Entry or Local Association. If the release is denied by the Local Association, the player has the right to a hearing at the Affiliated Association. All evidence and results of this hearing will be forwarded to the OBA and all parties involved. The player must appeal to the Affiliated Association prior to appealing to the OBA. If the Affiliated Association refuses the release, the player may appeal to the OBA Technical Committee in writing. The Technical Committee will establish the time and place of the appeal hearing which will be held within 30 days of receiving the written appeal. The appellant and the responding Direct Entry or Local Association and Affiliated Association must be present in person at the hearing to provide evidence in support of their position. Failure to appear may result in a

default decision. The decision of the OBA Technical Committee shall be final. Releases shall not be valid until filed with the OBA Office.

- c) In the case of a player below Junior age who has been a bona fide and continuous resident of the municipality to which his/her Direct Entry or Local Association belongs before June first of the baseball season, wishing to change his/her Direct Entry or Local Association or residence, he/she must in addition to the forgoing provisions, sections a) and b), secure the written consent of his/her parent or guardian in order to make such a change.
- d) In the case of all players, 18 years of age and under, if their family makes a legitimate move from one area to another, a release from the Direct Entry or Local Association they were signed to and played with shall not be required. In the case the parent or guardians do not move, but the player makes a move from one area to another, then a release from the Direct Entry or Local Association that he/she was signed and played with the previous or last season is required.
- e) Players signed with one team must be properly released before signing a second roster. This clause applies to all series. Where a player has been released by his/her team, said release must be approved and signed by the registrar of the Affiliated Association of which his/her team is a member before such release is valid. Any player signing a new roster to play for another team or playing for a non-registered team before his/her release from the first team is signed, may be subject to suspension by the OBA Board of Directors.
- f) Any player who has not been played by his/her team in 3 or more consecutive league games has the right to appeal to the OBA Board of Directors should his/her team refuse to release him/her.
- g) Where a Local Association or Direct Entry grants a player a release, such release is valid and remains in full force and effect so long as the player continues to play for the Local Association or Direct Entry with which the player signed an OBA playing roster on the basis of having been granted such release.
- h) No player may participate in any game(s), practice(s) or tryout(s) with a team that does not hold his/her playing rights. A player must secure a release from the Direct Entry or Local Association (and Affiliated Association, if required by P-13 b) vi)), that holds his/her playing rights under these rules, before he/she may participate in any game(s), practice(s) or tryout(s) with any other team. Failure to do so will leave said player open to suspension by the OBA. A player may apply for a permission to practice form from his/her Local Association (and the Local Association where he/she played the previous year if different from the one in which he/she lives) that would allow player the opportunity to work-out with another specific team until a decision is made within his/her Local Association regarding fielding a team in the coming season and/or securing a release from his/her Local Association.
- i) Any coach or manager who allows a player to participate in any game(s) or practice(s), with a team that does not hold his/her playing rights will leave said coach and/or manager open to suspension by the OBA.
- j) No player, coach or manager may approach any other player for whom their Local Association or Direct Entry does not hold the playing rights with the intention of securing said player for their Local Association or Direct Entry without the permission of the Direct Entry or Local Association (and Affiliated Association, if required, by P1-3 b) vi)), that holds the player's playing rights. Violation of this rule will leave the player, coach and/or manager open to suspension by the OBA. Where an director, officer, employee or other member of a Local Association or Direct Entry who is not also a player, coach or manager approaches any player for whom their Local Association or Direct Entry does not hold the playing rights with the intention of securing said player for their Local Association or Direct Entry without the approvals listed above, then such violation will leave the Local Association or Direct Entry of the director, officer, employee or other member open to a fine of up to \$1000.

Section P1.5 PLAYERS MAY ADVANCE TO HIGHER SERIES

- a) A player in any series Junior or below shall be allowed to advance on his/her having signed a team roster and compete with a team in each higher series in his/her own Local Association without affecting his/her status in the series and classification in which he/she signed. Any player who advances must play with his/her original team when the team he/she advances to and the team he/she signed with have games on the same date. (**Note:** Any team knowingly postponing a game so that a player may advance will be suspended from the OBA Play-offs.) (Local Association shall be interpreted to be the one in which the player is signed.)
- b) A player may advance as follows:
 - i) A Rookie may advance only to Mosquito, (Note: A Rookie Ball player is not eligible to pitch.)
 - ii) A Mosquito may advance only to PeeWee,
 - iii) A PeeWee may advance only to Bantam,
 - iv) A Bantam may advance only to Midget.
- c) For clarification, where a Local Association has more than one team at a series, players on one team are not eligible to be called up to the other team.
- d) Where a player of a younger age is rostered with a team at an older age category (eg. A PeeWee aged player is rostered on a Bantam roster) shall be considered as a player of the older series at which he/she is registered despite being of younger age, and shall not be eligible to be called up to the younger team.
- e) Any team wishing to use a call up player from a team that has been eliminated from any further competition during a tournament or an OBA Play-off tournament or an OBA Elimination tournament must have a copy of the official team roster for the call up player. To be eligible to pitch, the team must have either the pitch count records or copies of the official game sheets involving the call up player. Any player that cannot verify his/her eligibility to pitch will not be allowed to pitch.

Section P1.6 PLAYER REGISTRATION

- a) A permanent identification number will be assigned to an OBA registered player based on his/her birth registration number. For players without a birth registration number, and not registered with the OBA before 1998, the OBA will assign a permanent identification number.
- b)
 - i) The OBA shall update the eligibility for a series for all previously registered players, based upon the player's birth year, at the beginning of each subsequent calendar year.
 - ii) Team rosters will be prepared by the OBA, by sorting the updated player information by Local Association or Direct Entry and by series. Team rosters shall be printed by the OBA showing all current player information, not including managers and coaches.
 - iii) The team rosters will be distributed by the OBA to the respective registrar of the Affiliated Association at or before the Secretary-Registrars' Meeting, to be held on a date established by the OBA.
 - iv) The Affiliated Association registrar shall distribute the team rosters to the Local Association, in the usual manner, within the Affiliated Association.
 - v) The team manager updates, as necessary, the information on the team roster to ensure that the information listed for each player is complete and accurate. Players who should not appear on the team roster are deleted by putting a single line through that player's information. Complete information for all new players to the team roster, is added, in ink, including date of birth and birth registration number. Complete information is added, in ink, for all team managers and coaches.
 - vi) After all information on the team roster has been confirmed or updated, the team manager shall have the parent of the player, if that player is under the age of 18, at the time of signing, or the player, if that player is of age 18 or older, at the time of signing, sign the team roster next to the player information. The signature shall indicate that the information is correct and that participation of the player shall be in accordance with the Constitution of the OBA.
 - vii) The team manager shall draw a line through all unused rows of the team roster. The team manager shall sign the bottom of the team roster, after all necessary changes have been made, accepting responsibility for the authenticity of the information shown on the team roster. The team manager shall submit the signed team roster to the Affiliated Association registrar, through the Local Association as appropriate, in the usual manner.
 - viii) The Affiliated Association registrar shall check the submitted team roster ensuring that all information is complete and accurate (i.e. players are registered for the proper team and series, birth records are confirmed, necessary player releases are included, etc.), that all required player releases for the current year are complete and accurate and that all registered coaches are properly certified, all unused rows have been deleted by a line through them, the complete team name and series is shown, etc.
 - ix) The Affiliated Association registrar approves the team roster by affixing his/her signature/stamp, thereby accepting responsibility for confirming that the team roster is complete and correct. The Affiliated Association registrar then submits the team roster, including where necessary, copies of birth records, releases, etc., to the OBA.
 - x) The OBA shall review the team roster submitted to ensure that the information for each player, coach and manager is complete, the signature of the team manager and the signature/stamp of the Affiliated Association registrar are on the bottom of the team roster and the required number of players and coaches is present (i.e. at least 1 manager/coach and a minimum of 9, maximum of 25 players), copies of birth records and player releases are attached as required, no player is registered in a series for which he/she is not eligible, etc.
 - xi) The OBA shall then update the player database from the team roster, making all corrections, additions or deletions, as submitted.
 - xii) The OBA shall print 3 copies of the team roster and deliver them to the Affiliated Association registrar.
 - xiii) The Affiliated Association registrar shall review the information on each team roster. If all of the information shown is correct, the Affiliated Association registrar shall sign/stamp all copies of the team roster. The Affiliated Association registrar shall retain one copy of the team roster and forward all remaining copies of the team roster to the Local Association and the team, in the usual manner. The Local Association, if appropriate, shall distribute the team rosters to its teams, in the usual manner.
 - xiv) The team manager shall have the player, regardless of his/her age, sign the team roster in the space provided. The team manager shall retain the team roster for presentation when requested.
- c) Player(s) being added to a team roster, subject to the deadlines noted below, after the team roster has been returned by the OBA, must be submitted on a blank team roster, following all of the procedures previously. The OBA, after updating the player database with the new player(s), shall print a revised team roster for the new player, and forward it to the Affiliated Association registrar. The Affiliated Association registrar shall review the new team roster and distribute it as noted previously. The Affiliated Association registrar is responsible for ensuring that all superseded team rosters are destroyed.
- d) Player(s) being deleted from a team roster, subject to the deadlines noted below, after the team roster has been returned by the OBA, shall be indicated by drawing a single line through that player's information on the team roster and the team roster resubmitted through the Affiliated Association registrar to the OBA, following all of the procedures previously. The OBA, after updating the player database with the deletion(s), shall print a revised team roster, and forward it to the Affiliated Association registrar. The Affiliated Association registrar shall review the new team roster and distribute it as noted previously. The Affiliated Association registrar is responsible for ensuring that all superseded team rosters are destroyed.
- e) All team rosters must be sent to the OBA Office on or before June 30th, of the current playing year, except by Affiliated Associations with an approved OBA Registrar, for whom the date is July 8th, of the current playing year. Team rosters submitted to the OBA, not completed correctly, must be resubmitted to the OBA Office no later than August 8th of the current playing year. Where an entire team (which is playing an Affiliated Association schedule prior to June 30) fails to submit a roster to the applicable Affiliated Association registrar or the OBA Office within the time frames contemplated by this section, the team may register late upon paying a

\$500 late registration fee to the OBA. In so registering, the team must provide evidence satisfactory to the OBA Registrar that the players listed as being part of such team were part of such team prior to June 30. **Note:** This provision does not permit individual players to be added to team rosters after June 30.

- f) No player shall be added to a team roster before September 15th of preceding year, nor after June 30th of the current playing year.
- g) Affiliated Associations must forward all team rosters and certificate tax for all of their players and teams whether they participate in the OBA Play-offs or not. Team managers shall ensure that the signature/stamp of the OBA Registrar or designate, is on the team roster. No player may participate in an OBA tournament or Play-off without his name on a team roster, unless otherwise approved by the OBA.
- h) Where this section refers to the OBA printing or providing team rosters, the same may be provided in electronic form.

Section P1.7 TEAM NUMBER

A team must have 9 signed players and may have a maximum of 25 players who must be signed to a team roster of the series of the team entered. Each team must have at least 1 manager, and/or 1 or more coaches, signed to the roster clearly marked “Manager” or “Coach” and who shall be responsible for that team.

Section P1.8 PROFESSIONAL PLAYERS AND REINSTATEMENT

- a) Any player signed by a professional baseball club of the National or American Leagues of Professional Baseball Clubs, or of the National Association of Professional Baseball Leagues, who has received his/her unconditional release or has been placed on the Voluntary Retired List by said professional club before June 30th of the playing season shall become eligible for reinstatement to play in the OBA immediately when he/she returns to his/her home city or town, or to the team he/she left to turn professional or he/she may play with any other team providing he/she qualifies under the residence rule.
- b) All applications for reinstatement must be accompanied by a letter from the Office of the President of the National Association of Professional Baseball Leagues or a copy of the release from the applicable professional organization.
- c) A player shall be considered to have turned professional when he/she plays his/her first game, either exhibition or league with a professional club.
- d) The release or voluntary retirement must accompany any application for reinstatement.

Section P1.9 ELIGIBILITY

- a) Players are not eligible to register with the OBA for the then current playing season if they have registered with a non-recognized baseball program operating in the Province of Ontario for any part of such playing season. Players registered with the OBA for the then current playing season who register with a non-recognized baseball program shall be subject to suspension in accordance with section P7-1.
- b) Where an entire team of players desires to register as a team with a non-recognized baseball program, the Local Association operating such team may, if it has the approval of its Affiliated Association, apply to the OBA for OBA recognition of the non-recognized baseball program. The OBA may in its absolute discretion recognize or refuse to recognize such other baseball program.
- c) Individual players may participate with a non-recognized program outside of the province if he secures letters of permission from: (1) OBA Coach and/or Manager (2) Local Association Executive and (3) Affiliate Association Executive; allowing him/her to play with a specified team or organization. (All letters and information shall be forwarded to the OBA through the Affiliated Association)
- d) For the purpose of this section P1-9, the following terms shall have the following meanings:
 - i) “non-recognized baseball program” shall mean any baseball program other than (1) a baseball program operated exclusively by the OBA, its Affiliated Associations and its Local Associations, (2) a high school, college or university baseball program, (3) a baseball program operated exclusively by an associated member of the OBA, (4) a baseball program sanctioned by the OBA Board of Directors, or (5) a baseball program operated by the PBLO in accordance with the PBLO Agreement.
 - ii) playing season” shall mean the period from May 15 through to the end of the Labour Day weekend.
 - iii) “registered” includes any form of signing or registration process and any player participating on a regular basis with a non-recognized baseball program shall be deemed to have been registered with such program.
- e) A player participating in another recognized program shall have the right to sign only with:
 - i) the OBA Local Association in whose territory the player lives or
 - ii) the OBA Local Association with whom the player played in the previous playing season.

If the player is not signed by such Local Association, then he/she shall not be entitled to sign with another Local Association.

Senior players are exempt from P1-9 e).

Section P1.10 PBLO

- a) The terms of the PBLO Agreement shall govern teams operated by PBLO Franchises.
- b) The provisions of Sections P1-1, P1-2, P1-3, P1-4, P1-5, P1-6 and P1-7 shall not apply to teams playing in the PBLO unless the Franchise operating such teams determine to operate as a Residency Franchise in which case those provisions shall apply to the teams operated by such Residency Franchise.

- c) The PBLO shall determine such residence and release requirements, if any, as shall apply to PBLO Non-Residency Franchises.
- d) The PBLO shall determine such registration procedures and policies as shall apply to PBLO Franchise teams.
- e) PBLO Non-Residency Franchises may not operate teams other than as set out in the PBLO Agreement. Accordingly, Affiliated Associations and Local Associations may not operate PBLO Non-Residency Franchises. However, since PBLO Residency Franchises may operate additional teams, Affiliated Associations and Local Associations may operate PBLO Residency Franchises.
- f) Players playing on a PBLO Non-Residency Franchise team may also register with a team of a Local Association in accordance with P1-9 e) i) or ii).
- g) Players playing on a PBLO Residency Franchise may not sign with another team.
- h) PBLO Non-Residency Franchise teams are not eligible to compete in OBA Elimination tournaments and/or OBA Play-offs, other than the AAAA championships determined by PBLO. PBLO Residency Franchise teams are eligible to compete in OBA Eliminations and/or OBA Play-offs at the AAA level.
- i) The provisions of P2, P3, P4, P5, P6 and P7 do not apply to the PBLO, PBLO Franchises or PBLO Franchise teams.

P2 SPECIAL PLAYING RULES

The Official Rules of Baseball shall govern all games except as provided in the playing rules below.

Section P2.1 REPORTING ABUSE

Any incident that is considered to be verbal or physical abuse of or by any participants in any OBA games shall be reported by the tournament convenor(s), OBA officials and/or the umpire(s) to the OBA Office.

Section P2.2 GIRLS BASEBALL

Only females are eligible to play Girls Baseball.

Section P2.3 PROHIBITION ON THE USE OF TOBACCO PRODUCTS, ALCOHOL AND DRUGS

- a) Players, coaches and umpires in uniform must refrain from using any tobacco products during all games.
- b) Players, coaches and umpires in uniform must not be under the influence of alcohol or drugs.
- c) Penalty for a) and b) will be immediate ejection for players or coaches and may result in loss of accreditation for umpires.

Section P2.4 COACHES AND MANAGERS

- a) All coaches and field managers, in order to be on an OBA roster after June 30 of the playing year, must have achieved one of the following:
 - i. NCCP trained status, which includes online initiation and workshop or
 - ii. NCCP Level 1, which includes technical, theory and practical.
- b) For OBA Elimination tournaments, coaches must meet the Baseball Canada certification requirements applicable to the national tournament they would attend if their team won the Elimination tournament.
- c) Managers and coaches will be responsible for the conduct of their players both on and off the field until departure from the park. An infraction may result in a suspension for the next scheduled game in that OBA Play-off or to further suspension depending on the severity of the circumstances of the incident at the discretion of the tournament host's protest and discipline committee. Nothing in this paragraph limits the application of P2-13.
- d) In Junior and below, at least one certified coach or manager listed in the Helpers Roster of the Local Association must be present and on the bench for each game. If there is no coach/manager present or the only coach/manager present is ejected, then the game is forfeited.
- e) All coaches and managers come under the jurisdiction of the umpires during games and are subject to penalties. The umpires shall see that the rules governing coaches and managers in all games are strictly enforced.
- f) As per the Official Rules of Baseball, in Minor Bantam and above, any team member in uniform may act as a base coach. Where a player in Minor Bantam, Bantam, Minor Midget or Midget is acting as a base coach, the player must wear a helmet.

Section P2.5 UNIFORMS/EQUIPMENT

- a) In all games in all OBA series, all team personnel, including the manager and coaches, must be in complete baseball uniform. Note: Complete baseball uniform shall consist of:
 - corresponding tops or jerseys (with proper numbers),
 - corresponding (similar) baseball caps
 - baseball pants (no shorts)
 - corresponding stirrup or baseball socks.
- b) Provided the teams are completely uniformed the uniformity as laid down by the Official Playing Rules of Baseball will be disregarded and no protest will be considered by the OBA after the game has been played.
- c) The on deck batter, batter, base runners and batboy/batgirl must wear a prescribed protective helmet with flaps, covering both ears. This may not be changed except after the inning has been completed, or the player has been retired or has crossed home

plate. In Rookie Ball, T-Ball, Minor Mosquito, Mosquito, PeeWee Girls, Minor PeeWee and PeeWee, helmet chinstraps are mandatory and will be worn as designed by the manufacturer.

- d) In Rookie Ball, T-Ball, Minor Mosquito, Mosquito, PeeWee Girls, Minor PeeWee, PeeWee and Bantam Girls shoes with metal cleats are prohibited.
- e) All catchers are required to wear a mask with throat protector, helmet, chest protector, shin guards, cup and a cup-type supporter.
- f) Any team member serving as a catcher to warm up a pitcher shall wear a mask with throat protector.
- g) In addition to wooden bats, metal bats shall be allowed in OBA play. Subject to the following sentence, these bats shall meet the dimensional requirements, specified in rule 1:10 of the Official Rules of Baseball. All bats used in:
 - Bantam will not exceed 2 3/4" in diameter, and will not have a weight to length differential of greater than five ounces
 - For all Minor Midget, Midget, Junior and Senior OBA play, only wood bats (including composite wood bats) shall be permitted. Metal/Wood bats are not to be considered wood bats.
- h) Pitchers will be allowed to wear Medic-Alert bracelets on the wrist of their pitching arm if such bracelets are locked or cannot be transferred to their non-pitching wrist.
- i) There is no visible jewellery allowed.

Section P2.6 APPROVED BASEBALLS

MAKE	MODEL	MANUFACTURER'S RECOMMENDED USE
WORTH	CTB4	T-Ball and Indoor Use
	BCAF	Minor Mosquito to Peewee
	MLH	Minor Peewee to Senior
RAWLINGS	TVB	T-Ball and Indoor Use
	ROTB5	Rookie
	ROLB1	Minor Mosquito to Bantam
	65CC**	Minor Mosquito to Bantam
	80CC**	Minor Peewee to Senior
	ROML*	Minor Peewee to Senior
	ROLB	Minor Peewee to Senior
Diamond Sports	R100	Minor Bantam to Senior
	D1C	Midget and Up
	D2C	Peewee to Midget
Silverstar Sports	D3C	Bantam and Down
	818LS	Rookie to Peewee
	REV500	Peewee to Senior

* Official Ball of Baseball Ontario and Baseball Ontario Elimination Tournaments

** Official Baseball Of Baseball Ontario

Section P2.7 GAME LENGTH

- a) All games in an OBA Play-off or Elimination Tournament shall be 7 complete innings (6 1/2 complete innings if the home team is ahead), or until a winner is declared.
- b) In tournament play if a game is delayed due to curfew, darkness, light failure or weather related conditions at any point prior to completion, the game shall be resumed from the point of delay.
- c) In the case of bad weather or other emergency situations, the schedule may be revised at the discretion of the Tournament Committee.
- d) In home and home style OBA Play-off games called due to curfew, darkness, light failure or weather related conditions after becoming an official game shall be declared a complete and official game even if less than 7 innings were played. If the game is called prior to becoming an official game, then it is resumed from the point of delay.
- e) Time limits are not permitted in any OBA Play-off or Elimination games.
- f) In Open or Invitational Tournaments when a time limit or curfew is in effect in the tournament rules, it shall be interpreted as follows: No new inning may be started after the time limit or curfew.
- g) In all OBA games an 18 run mercy rule will apply after 3 innings (2 1/2 if the home team is ahead) and a 10 run mercy rule will apply after 5 innings (4 1/2 if the home team is ahead).

Section P2.8 LINE-UP RULES

- a) Each manager will see that the umpire-in-chief is provided with a batting order card listing the batting order of his/her players for the commencement of the game. This card shall list (i.e., print legibly) each player's first and last name, his/her uniform number and position. It shall also list the substitute players, coaches and manager including their uniform number. Bona fide players of either team, who arrive after the commencement of the game, may have their names added to the list upon reporting to the umpire-in-chief.
- b) In Minor Mosquito and Mosquito games, all players present at the game shall be listed on the team's batting line-up in the order desired by the manager/coach and bat in that order. Late arrivals shall be added to the bottom of this batting order.
- c) In Minor Mosquito and Mosquito games, if a player is removed from the game due to injury, illness or official ejection, the player's spot in the batting order shall be deleted. In the event a batter must be removed due to injury, official ejection, or has to leave for any reason during the time at bat, the next batter in the batting order shall come to bat assuming the balls and strikes count at the time the batter is removed. If the batter becomes an out, such batter shall then take his/her regular turn at bat.
- d) In Minor Peewee, Peewee, Minor Bantam and Bantam, teams may opt to utilize 10 batters in the starting line-up. The additional batter shall be deemed as the extra player (EP). The following rules for the EP shall apply:
 - i. The option to use the EP must be declared when handing in the line-up card prior to the start of the game.
 - ii. The EP may bat in any place in the batting order.
 - iii. The EP will be considered a defensive position and eligible for re-entry.
 - iv. If a team using the EP has any players ejected or injured and it results in the team having less than 10 players in the line-up the game shall continue with 9 players. The batting order will be shifted up to fill the void but otherwise remains the same.

Note: If the player starting in the EP is moved into a defensive position his place in the batting order does not change. The new EP will bat in the place of the player they replaced.

- e) A designated hitter may be used for a pitcher from Minor Midget to Senior as per the Official Rules of Baseball 6:10(b).
- f) A designated hitter may be used in any OBA Elimination Tournament only if it is permissible at national level.
- g) For tournament play the Tournament Convenor shall appoint an official scorer for each game (who may be the scorer of 1 of the teams playing). For all home and home style OBA Play-off games the home team score keeper shall be the official score keeper.

Section P2.9 SUBSTITUTIONS

- a) In Minor Mosquito and Mosquito games, unlimited substitutions defensively are allowed (including for injury or official ejection).
- b) In Minor PeeWee, PeeWee, PeeWee Girls, Minor Bantam, Bantam, Bantam Girls, Minor Midget, Midget, Women's and Junior ball any starting player may be substituted for and returned to the game, one time only. He/she must return to his/her original place in the batting order. Any further substitutions do not jeopardize the right of re-entry for the original/starting player. Any starting player returned to the game may pitch if he/she has not previously assumed that position. A pinch runner may be inserted for a pitcher, who was listed in the starting batting order, and the pitcher may return to pitch under this re-entry rule only if the player is re-entered immediately as a pitcher when his/her team takes the field defensively.
- c) In Minor PeeWee, PeeWee, PeeWee Girls, Minor Bantam, Bantam, Bantam Girls, Minor Midget, Midget, Women's and Junior ball in the event that all players have entered the game and an injury(s) occurs, the opposing manager shall have the right of selecting any remaining player(s) as the replacement.

Note: This rule does not apply to ejections from a game.

- d) If a player re-enters or enters the game illegally: offensively, this shall be considered as a batter hitting out of order; defensively, the proper player shall replace him.

Section P2.10 PITCHING RULES

- a) Any player advancing to play in a higher series shall be restricted to the pitching rule of the series in which he/she is registered.
- b) In Minor Mosquito and Mosquito games, the number of trips to the mound by manager/coach shall not be limited except when the umpire rules that the purpose of the trip is to delay the game.
- c) In Peewee Girls, Minor Peewee and Peewee games, a third trip by a manager/coach to the same pitcher in the same inning shall result in the pitcher's automatic removal from the pitching position.
- d) In Minor Mosquito, Mosquito, Peewee Girls, Minor Peewee and Peewee games, a pitcher once removed from pitching, regardless of the number of trips to the mound by the manager/coach, may continue in the game at another position, but shall not be permitted to return to pitch in that game.
- e) From Minor Bantam to Senior, a second trip by a manager/coach to the same pitcher in the same inning shall result in the pitcher's automatic removal from the pitching position. The pitcher, once removed after the 2nd trip in an inning, may continue in the game at another position but shall not be permitted to return to pitch in that game.

Pitch Count Limitations

- f) A pitcher may not pitch more than the following limits in a calendar day. If the limit is reached while facing a batter, the pitcher may pitch to the earlier of: (i) the completion of that batter or (ii) the end of the inning.

Minor and Major Mosquito	70 pitches
Minor and Major Peewee, Peewee Girls	80 pitches

Minor and Major Bantam, Bantam Girls	90 pitches
Minor and Major Midget, Women	100 pitches

- g) If a pitcher throws more than the following limits in a calendar day he/she cannot pitch the next day – the player must have 2 nights rest.

Minor and Major Mosquito	45 pitches
Minor and Major Peewee, Peewee Girls	55 pitches
Minor and Major Bantam, Bantam Girls	65 pitches
Minor and Major Midget, Women	75 pitches

- h) If a balk is called but the pitcher throws the ball it will count as a pitch thrown, even if it is not counted as a pitch for ball/strike purposes.
- i) The official scorekeeper shall designate the official pitch count recorder.
- j) The official pitch count recorder must provide the current pitch count for any pitcher when requested by either manager or the umpire.
- k) The official pitch count recorder shall inform the home plate umpire when a pitcher has delivered his/her limit of pitches for the game. The home plate umpire will then notify the pitcher's manager that the pitcher must be removed.

Note: It is the responsibility of the manager to remove a pitcher when that pitcher is no longer eligible, even if the pitch count recorder and/or the umpire fail to notify the manager.

- l) If a team has no remaining players eligible to pitch in a game, the opposing coach may designate a player who has yet to pitch in the game. This pitcher may not throw more than 30 pitches. If the limit is reached while facing a batter, the pitcher may pitch to the earlier of (i) the completion of that batter, or (ii) the end of the inning.

- m) Illegal pitching penalty: where a player throws more pitches than is permitted under f); or pitches on 3 consecutive days in violation of n); or pitches and catches in the same game in violation of o), the penalty shall be forfeiture by the player's team. A second violation by a team will result in the manager/head coach's indefinite suspension.

n)

- i. At Minor Mosquito, Mosquito, Minor Peewee, Peewee, Peewee Girls, Minor Bantam, Bantam and Bantam Girls, pitchers may not pitch on 3 consecutive calendar days

- ii. At Minor Midget, Midget, pitchers may not pitch on 3 consecutive calendar days unless:

1. the pitcher threw 30 pitches or less on each of the first two days.
2. the maximum number of pitches which may be thrown on the third day is 50.

- iii. At Junior, Senior and Womens, there is no restriction on pitchers pitching on 3 consecutive calendar days.

- o) At Minor Mosquito, Mosquito, Minor Peewee, Peewee and Peewee Girls, a player may not be a pitcher and a catcher in the same game.

- p) Pitches shall count on the calendar day on which the pitch is thrown. An exception shall be made where a game commences on one day and is played continuously past midnight. In that case, the pitches shall count as being thrown on the day on which the game commenced. In the case where a game is suspended, for whatever reason, on one day and resumed on a second day, pitches shall count on the calendar day on which the pitch is thrown (i.e. both parts of the game shall be considered on separate days). Where weather or other reasons cause the delay or postponement of a game or games, the time of the delay can count towards the nights rest required under g) and can constitute a break in the 3 consecutive day rule under n).

Section P2.11 BASE RUNNING RULES

- a) In Minor Mosquito and Mosquito, base runners cannot leave the base until the ball leaves the pitcher's hand. If an infraction occurs, the ball will be declared dead and runners may not advance. 1 warning will be issued and for any further infractions thereafter, the runner will be called out. (Each team to receive 1 warning).
- b) In Minor Mosquito and Mosquito, if a runner is removed by reason of injury or official ejection from the game, the player last put out shall act as pinch runner for the removed player. By virtue of the rule there shall be no pinch runners allowed.

Malicious Contact:

- c) Malicious contact is to be penalized whether committed by an offensive or defensive player. Contact shall be considered malicious if:

- i. the contact is the result of intentional excessive force, and/or
- ii. there is an intent to injure.

- d) The umpire shall determine whether contact was avoidable or unavoidable. If the fielder blocks the base path, the runner may make contact, slide into or collide with the fielder as long as the runner is making a legitimate attempt to reach the base/plate.

- e) Runners are instructed to slide or attempt to avoid making contact with a fielder. A player who maliciously runs into another player is to be declared out (unless he/she has scored prior to committing the infraction) and is to be automatically ejected (whether or not declared out).

- f) If the defensive player blocked the base path clearly without possession of the ball, obstruction shall be called. The runner is safe and a delayed dead ball is called.

Section P2.12 FIELDING RULES

- a) A fielder may not enter the dugout or bench area to make a legal catch. Any such ball shall be declared dead.

- b) Where a fielder carries a live ball into dead ball area, the ball shall be declared dead and all runners shall be awarded 1 base without liability of being put out.

Section P2.13 EJECTIONS

Any player, coach or manager ejected by an umpire from any OBA Play-off or Tournament (Elimination, Play-off or other sanctioned tournament) game is suspended for 1 game, and this to be the next scheduled game in that tournament or Play-off. The player, coach or manager may be subject to further suspension depending on the severity of the circumstances leading to the ejection at the discretion of the tournament host's protest and discipline committee.

Section P2.14 PROTESTS

- a) Protests based on umpires' judgment decisions will not be permitted.
- b) A protest based on an umpire's interpretation of the rules must be lodged with the umpire before the game resumes, and the opposing team must also be advised by the umpire before the game resumes.
- c) No protests will be entertained regarding coaches or managers being listed on a roster team. A coach or manager signed with 1 team in an organization may act as coach or manager for any other team in that organization.
- d) Tournament Style Play-offs:
 - i. A Protest Committee shall be established by the host Local Association.
 - ii. The Protest Committee has the right to rule whether a protest will be heard.
 - iii. All protests must be ruled on at the time of their occurrence by the Protest Committee.
 - iv. If the protest is heard and denied, the team will be billed \$50.
- e) Home and Home Style Play-offs:
 - i. Protests are to be mailed to the Protest Chair postmarked within 48 hours of the end of the game under protest. The \$50.00 fee will accompany it.
 - ii. Copies of the protest are to be sent to (1) the OBA President (2) the OBA Office (3) the Series Chair and (4) the manager of the other team.
 - iii. The Protest Chair will decide on behalf of the President, whether there is reason for holding a protest meeting.
 - iv. The site and time of the protest meeting will be decided by the Protest Chair.
 - v. Results of the protest hearings will be sent by the Protest Chair to the OBA President, both teams, the OBA Office, the Series Chair and the Overall Series Chair.
- f) Once a protest has been dealt with by the OBA or a committee delegated to act in such matters by the OBA, any ruling handed down must be considered as final by the OBA. No further action will be taken.
- g) The Protest Chair has the power in a home and home style OBA Play-off to appoint a committee to handle all protests which must be disposed of 5 days from the time the Protest Chair receives the complete protest, etc.
- h) Each team may be represented at the hearing by 2 representatives, only 1 of whom shall be permitted to speak. Where Direct Entries, Local Associations, Affiliated Associations or teams are only called in to give evidence they shall not be required to deposit a defence fee.
- i) All correspondence regarding protests and defence of appeals must be forwarded by registered mail.
- j) Even if it is held that the protested decision violated the rules, no replay of the game will be ordered unless in the opinion of the Protest Chair the violation adversely affected the protesting team's chances of winning the game.
- k) Teams or players which knowingly play against ineligible players and do wilfully conceal this knowledge from the OBA until it shall suit their convenience to use it in any protest which may arise shall be considered equally guilty with the offending team or players and shall be dealt with accordingly.

Emergency Situations:

- l) In an emergency situation the protest will be dealt with by the Series Chair in consultation with the OBA Protest Chair and the OBA President.

P3 UMPIRES

Section P3.1 GENERAL

- a) The home team in a home and home style OBA Play-off shall notify and supply official OBA umpires. All umpires are to be classified as neutral. Any visiting team which wishes a change of umpires for the third or deciding game only, may request same through their Series Chair, but must pay the umpires' mileage or any other extra cost that may occur.
- b) All umpires and umpires' associations must be first approved by the Affiliated Association before they may qualify as registered OBA umpires. The OBA Umpiring Supervisor shall determine annually the umpires to be registered with the OBA. The umpire is to pay a registration clinic fee per year as determined by the OBA for which an umpire's card, crest, OBA Playing Rules and Regulations, Official Rules of Baseball and accident and liability insurance will be issued.
- c) A list of OBA registered umpires, with their municipality and telephone numbers, will be furnished by the OBA to all Affiliated Associations and Series Chairs. All registrations are to be renewed yearly.

- d) All umpires who have been approved and recommended should affiliate with an umpires' association in their district. Where none now exists an umpires' association should be formed. This association in turn shall affiliate with the Affiliated Association in their area. In districts where there are no Affiliated Associations established, the Direct Entries making application for direct entry into the OBA must follow the same procedure and recommend the names of umpires to be registered.
- e) Umpires handling OBA games must have an OBA Umpire Card. An umpire may not officiate any OBA game involving a team of which the umpire is a member, without the written consent of both managers.
- f) All umpires must show their OBA umpire's card to managers of teams and OBA Convenors in a home and home style OBA Play-off. The umpire-in-chief must file a complete report to the OBA Office, concerning accidents, ejections, delays in starting and protests. This report is to be signed by the umpire-in-chief and the base umpires. Reports must be forwarded for each game within 24 hours of scheduled time of game. In tournament play it is the responsibility of the host to ensure that all umpires are officially carded and recognized by the OBA. If any umpire used in a tournament is found not to be registered with the OBA and game(s) are played using the umpire, the game results shall stand, however, the host shall be fined \$100.00 for each incident and may be refused as host for any tournaments in the succeeding year.
- g) All umpires shall be properly dressed as specified by the OBA Umpiring Committee when officiating at any baseball games involving OBA teams. Failure to comply could mean loss of accreditation.
- h) In all final series of a home and home style OBA Play-off, 3 umpires will officiate with the exception of the Minor Mosquito, Mosquito, PeeWee Girls, Minor PeeWee and PeeWee where 2 umpires will suffice. In tournament style OBA Play-offs 2 umpires will suffice except for the final game(s) at Minor Bantam, Bantam Girls, Minor Midget, Midget, Junior, Women's and Senior where there will be 3 umpires. 2 umpires will suffice for the final game(s) at T-Ball, Rookie Ball, Minor Mosquito, Mosquito, PeeWee Girls, Minor PeeWee and PeeWee.
- i) To qualify for a Baseball Ontario umpires card, an umpire must:
 - Level 1
Yearly attend a recognized Baseball Ontario umpire clinic.
 - Level 2
Yearly attend a recognized Baseball Ontario umpire clinic and pass a written test. Must be a Level 1 umpire for at least 2 years.
If the test is not successful, the umpire will be certified Level 1.
 - Level 3
Yearly pay a certification fee and pass a written test. Must be a Level 2 umpire for at least 3 years.
Every three years attend a recognized Baseball Ontario umpire clinic.
If the test is not successful, the umpire will be certified Level 2.
- j) Umpire Levels And Respective Series Effective Are:
 - Level I All House League, and Rep up to and including PeeWee
 - Level II Rep up to and including Midget
 - Level III Up to and including Senior
 - Level IV National Accreditation
 - Level V International Accreditation

Section P3.2 FEES FOR UMPIRES

- a) Umpires' fees for OBA Play-offs will be determined locally.
- b) Mileage allowed for OBA umpires is \$0.47 per kilometre for all series. If umpires are requested from outside their respective Local Associations, mileage allowed will be for each umpire unless 2 or more come from the same city or town in which case, only 1 will be paid mileage allowance.
- c) In all OBA Play-off games which are postponed because of rain or other causes, if umpires arrive before notification of postponement, they shall be paid ½ of the fees plus mileage if applicable. If game has been started, the umpires will be entitled to full fees and mileage, if applicable.
- d) No umpires will be paid by the OBA. The home team in each game of a home and home style OBA Play-off must pay the umpires' fees.

FIELD DIMENSIONS

Series	Mound	Bases	Diagonal	RECOMMENDED GUIDELINES				Grass Radius
				Foul Area	Outfield Fence			
					Left	Centre	Right	
	A	B	C	D	E	F	G	H
Regulation	60'6"	90'0"	127' 3 3/8"	60'	325'	400'	325'	95'
Bantam Girls	55'0"	82'0"	115' 11 5/8"	55'	300'	365'	300'	85'
PeeWee	50'0"	75'0"	106' 3/4"	50'	270'	335'	270'	80'
PeeWee Girls	50'0"	75'0"	106' 3/4"	50'	270'	335'	270'	80'
Mosquito	44'0"	65'0"	91'11"	44'	235'	290'	235'	70'
Rookie Ball	44'0" ‡	65'0"	91'11"	44'	235'	290'	235'	70'
T-Ball	50'0"	60'0"	84' 10 1/4"	40'	215'	265'	215'	50' ‡

‡ – measured from the centre of the Playing Line. ‡ – located at the centre point of an 8' diameter safety circle.
 The respective dimensions for any Series shall be deemed to include the corresponding Minor Series, except where noted

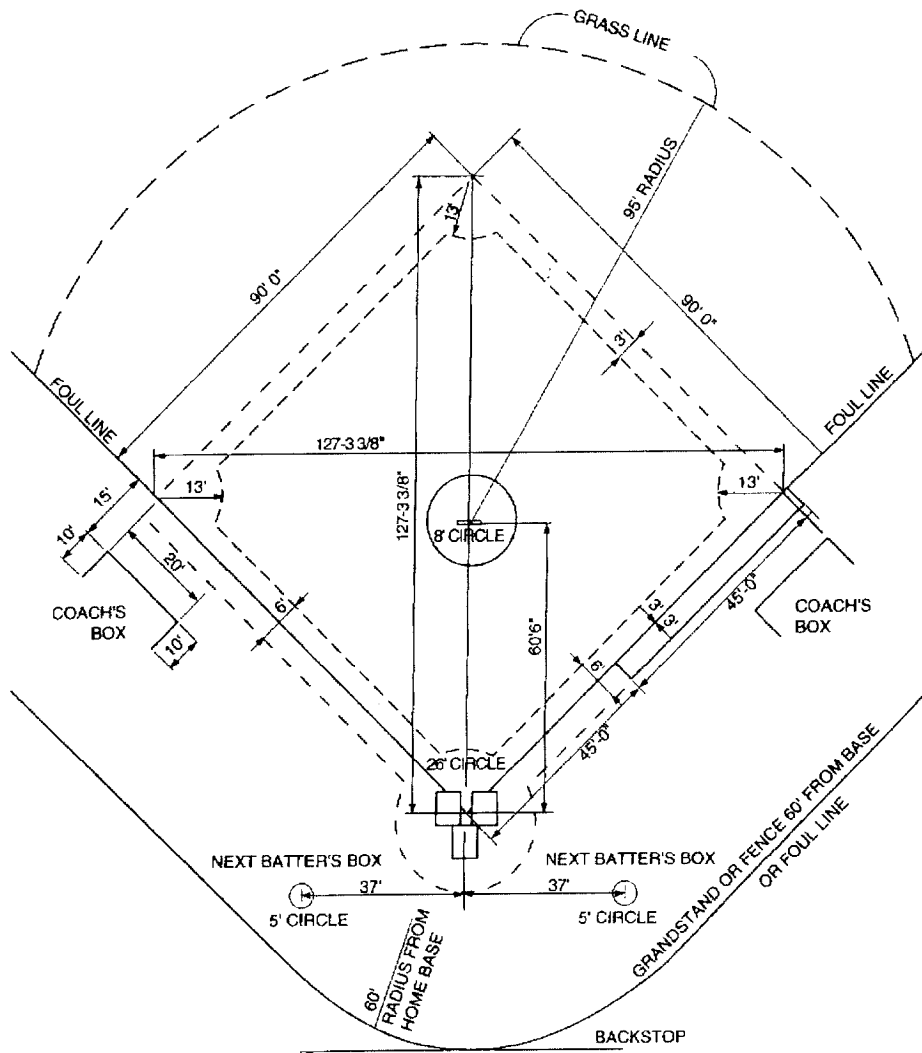

DIAGRAM NO. 1

LEGEND

- BATTER'S BOX, CATCHER'S BOX, FOUL LINE, PITCHER'S PLATE, COACH'S BOX
- NEXT BATTER'S BOX
- - - - BASE LINES
- - - - GRASS LINES

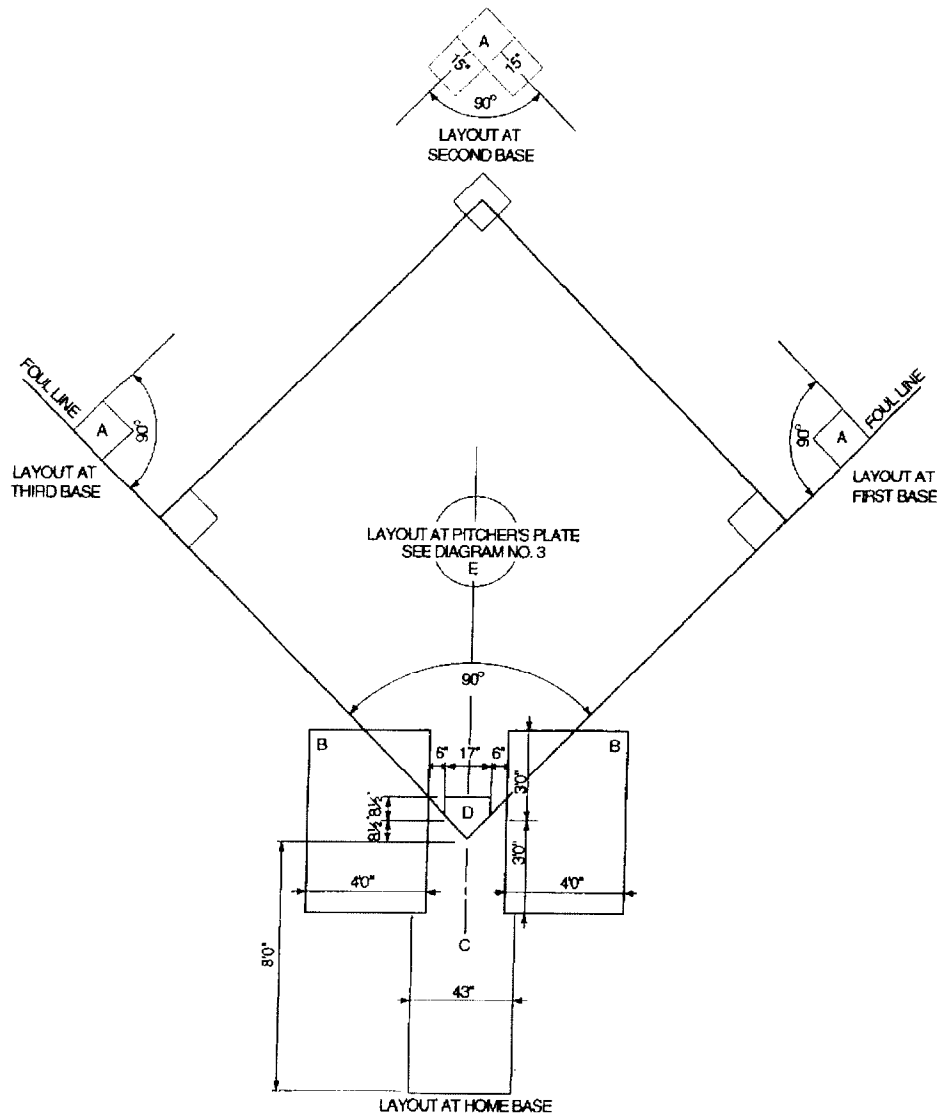

DIAGRAM NO. 2

LEGEND

- A 1st, 2nd, 3rd BASES
- B BATTER'S BOX
- C CATCHER'S BOX
- D HOME BASE
- E PITCHER'S PLATE

OBA PLAY-OFF PROCEDURES

- a) The OBA shall conduct and assist the different Affiliated Association representatives to meet and play off to determine the OBA champions.
- b) The OBA Board of Directors shall appoint a Series Chair to handle each series OBA Play-offs.
- c) In order to be eligible to participate in the OBA Play-offs, teams must represent a city, town or municipality within the boundaries of the Province of Ontario. Players must be bona fide and continuous residents of the province in accordance with the OBA Rules and Regulations.
- d) Whenever possible, the OBA Play-offs shall be a tournament. If no host is found by the July meeting of the OBA Board of Directors, then that series shall become a home and home style OBA Play-off. Except for Minor Mosquito, Minor PeeWee, Minor Bantam and Minor Midget (“minor age series”) OBA Play-off Tournaments will be comprised of 1 team from each Affiliated Association, which has classified a team for such OBA Play-off Tournament, plus a host team. At a minor age series, the OBA Play-off Tournament may, at the discretion of the OBA Board of Directors, be a tournament open to all teams of the minor age series registered with the OBA. If a minor age series tournament is to be such an open tournament in any year, the provisions of section 2.04 o) of the OBA Constitution and By-Laws shall not apply to such minor age series for that year.
- e) The Junior A OBA Play-off will be the Junior OBA Elimination Tournament.
- f) Coaches must have a copy of their OBA approved roster with them in case it is required during the tournament. The coach must write their OBA roster number in the space provided on the sign-in sheet. Failure to do so will result in the team being assessed a fine of \$200.
- g) Barring extenuating circumstances, if 1 team is not able to start a game within 30 minutes of the scheduled starting time for such game, the game will be forfeited to the other team and in tournament style OBA Play-offs, the offending team will not be allowed to continue in the tournament. The game will count as a game played and not count as a bye in the tournament and the published chart shall not be changed.
- h) Any team failing to play a game when ordered will automatically forfeit their right to continue in OBA Play-offs. This causes a \$500.00 fine to be assessed to the team forfeiting. A team that has been suspended shall have the right to appeal to the OBA Board of Directors for a hearing. All appeals must be accompanied with a fee of \$50.00.
- i) The OBA Tournament Chair shall provide, immediately, to the Affiliated Associations a listing of any and all disciplinary problems with managers, coaches, players or other team personnel, as reported by the Series Chair.
- j) In all OBA Play-off games, the diamond must be properly laid out; the batter’s box marked; the pitcher’s mound properly built up and the playing field kept sufficiently clear of spectators and obstructions for the proper performance of the players.

Tournament Style Play-Offs

- k) When the number of entrants to a tournament-style OBA Play-off is restricted by other organizations, such as those tournaments played during the Ontario Summer Games, a preliminary round(s) shall be arranged to provide the necessary representatives. Where such preliminary rounds are required to reduce the number of entries, the names of all Affiliated Associations with teams in that Series shall be entered into a draw to determine the pairing(s) of the preliminary round(s). Where such preliminary rounds are required to increase the number entries, the names of all teams in that Series (after the determining the Affiliated Association representatives) shall be entered into a draw to determine the pairing(s) of the preliminary round(s).
- l) Each Affiliated Association shall notify the OBA Series Chair by Tuesday midnight in advance of the start of the first game of the OBA Play-off Tournament, of its representative in that series and classification. Failure to make such information available by the required deadline, to the Series Chair, shall result in the Affiliated Association forfeiting its place in the OBA Play-Offs, subject to P5 g), plus any other penalty that might be imposed by the OBA.
- m) A committee shall be formed in each Affiliated Association to make the draws for all tournament style OBA Play-Offs within that Affiliated Association.
- n) The host shall designate a Tournament Convenor to convene the tournament. The Tournament Convenor shall not be a member of the host’s team in such tournament.
- o) No team may play more than 3 games in a calendar day, without written consent of the team. A suspended game shall count as a game played on both the day it commenced and the day it is completed if 3 or more innings have been played each day. If less than 3 innings are played on the day it is completed, it will not count as a game played on that day.
- p) Before distribution to the teams by the Tournament Host Association the complete schedule must be forwarded to the OBA Tournament Chair at least two weeks prior to the tournament for approval.
- q) Teams must be prepared to play on the Friday no earlier than 9:00 a.m. if necessary. In all series up to and including Bantam, no game shall start after 9:30 p.m. on any day and no new inning may begin after 12:59 a.m. (or such earlier time as may be provided by local by-law).
- r) Where a team drops out of a tournament style OBA Play-off 7 or more days prior to the start of the tournament, the schedule for the tournament, if published, will be redone. If a team drops out of a tournament style OBA Play-off less than 7 days prior to the tournament and the schedule for the tournament has been published, any scheduled games not played due to teams

- having dropped out of the tournament shall be considered defaults and shall count as a game played and not as a bye in the tournament and the published chart shall not be changed.
- s) The OBA Play-off Tournament host convenor shall be responsible for obtaining a copy of all applicable team rosters and submitting the copies to the OBA Tournament Chair. Failure to comply with such provisions will lead to the OBA Play-off Tournament host being fined \$200. A team, not submitting to the OBA Play-off Tournament host convenor an approved roster, will be suspended immediately and a \$200 fine will be assessed.
 - t) The tournament host is responsible for ensuring that each umpire is properly carded. The tournament host will maintain a sign-in list for all umpires used in the tournament and forward the sign-in list to the Tournament Chair with the Tournament Report.
 - u) Teams must be given a minimum of 30 minutes from the time of completion of the last game that they played, until the start of their next game. If a team must travel from another location, appropriate travel time shall be added to the 30 minute period.
 - v) Byes are to be awarded as follows:
 - i. No team shall receive a back-to-back bye in successive rounds.
 - ii. No team shall receive a second bye until all remaining teams have received their first bye.
 - iii. If more than 1 team is eligible for a bye, the undefeated team shall automatically receive the bye.
 - iv. If more than 1 team is eligible for a bye, the bye team will be determined by means of a draw with the first team drawn receiving the bye and the remaining teams drawn to fill each game slot from top to bottom as drawn.
 - w) The OBA Convenor's Report and specified attachments must be mailed (postmarked) to the OBA Tournament Chair within 10 days following the tournament.

Home and Home Style Play-Offs

- a) The secretary of each Affiliated Association shall notify the OBA Series Chair as to the representatives of his/her Affiliated Association, after which all arrangements regarding OBA Play-offs are to be completed through the management of the teams and respective Series Chair.
- b) All series shall be the best 2 out of 3; except in the final series in any category, if both teams agree, a longer series may be permitted. The OBA Board of Directors shall reserve the right to order a sudden death game in any semi-final or final OBA Play-off.
- c) In order that the final game may be played within a reasonable time, all teams competing in OBA games will be required to play 2 or more games a week.
- d) The home team shall have control of the arrangements for grounds, officials, convenors, etc. The said arrangements are subject to the approval of the OBA Series Chair.
- e) Where the home team operates under floodlights they shall reserve the right to play any or all the OBA Play-off games under the lights.
- f) No OBA Play-off game shall be scheduled before 1:00pm if the traveling team involved is further than 160 kilometres from location of said game.
- g) No playing member of either team involved in any series will be allowed to act as convenor.
- h) The Convenor making arrangements for OBA Play-offs must contact both teams personally regarding dates and times for all games and any further arrangements that might be necessary at least 48 hrs in advance of said dates and times.
- i) The game convenor will be responsible for checking the rosters prior to the game and returning the rosters to the respective teams.
- j) In all home and home style OBA Play-off games, the period for batting and fielding practice shall be: home team batting practice up to 45 minutes before advertised time of game; visiting team batting and infield practice for the next 30 minutes; home team fielding practice for the next 10 minutes. The home team shall be required to notify the teams of the termination of their allotted time for the various practices. It shall be the duty of the manager of the team at practice to order his/her team to vacate the diamond immediately. When a team is late for its allotted practice time they will forfeit their practice rights.
- k) All statements and OBA Play-off forms must be mailed (postmarked) to the Series Chair within 24 hours after each game.

Section P5.1 FORMAT FOR OBA PLAY-OFF TOURNAMENTS

(Available as a separate download from the website)

Note: Standard tournament formats for all OBA Play-off tournaments must be used, and those brackets not identified in this P5-6 will be provided by the OBA office to the tournament host before the close of business on the Friday following the OBA Classification Meeting.

SCHEDULE TO BE FOLLOWED FOR A 5 TEAM TOURNAMENT

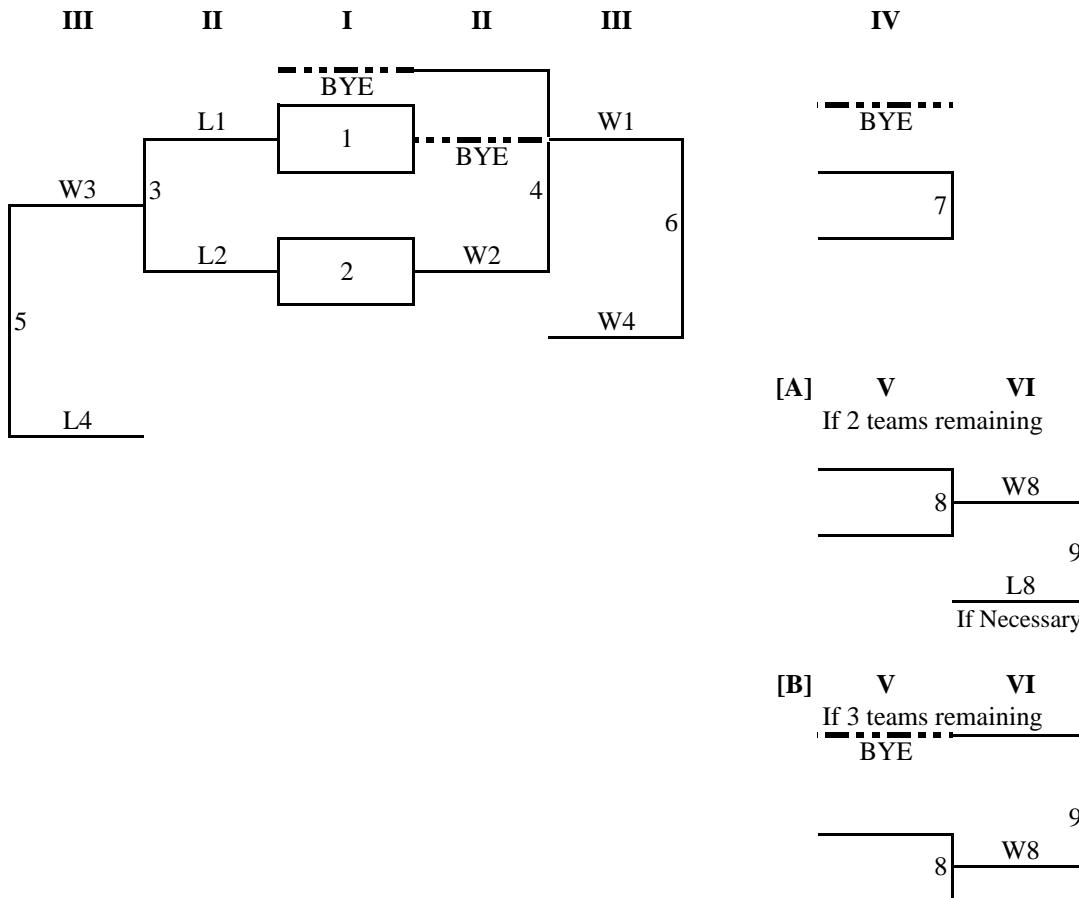

- Round I: Draw for bye and pairings.
- Round II: L1 plays L2. Bye team plays W2. W1 receives a bye.
- Round III: W3 plays L4. W1 plays W4.
- Round IV: At this point, L3 and L5 have been eliminated. Only 3 teams remain, 1 is undefeated. If the undefeated team is (3-0), it automatically receives the bye. If the undefeated team is (2-0), the bye goes to the team that has not yet had a bye. If more than 1 team is eligible for the bye, then draw for the bye. Please refer to section P5-1v) for rules applicable to byes.
- Round V: If the undefeated team won or received the bye in Round IV, only 2 teams remain (1 undefeated). Use Bracket A. However, if the undefeated team loses in Round IV, 3 teams remain, all with 1 loss. Draw for the bye. Use Bracket B.
- Round VI: If necessary, there will be a sudden death championship game.

SCHEDULE TO BE FOLLOWED FOR A 6 TEAM TOURNAMENT

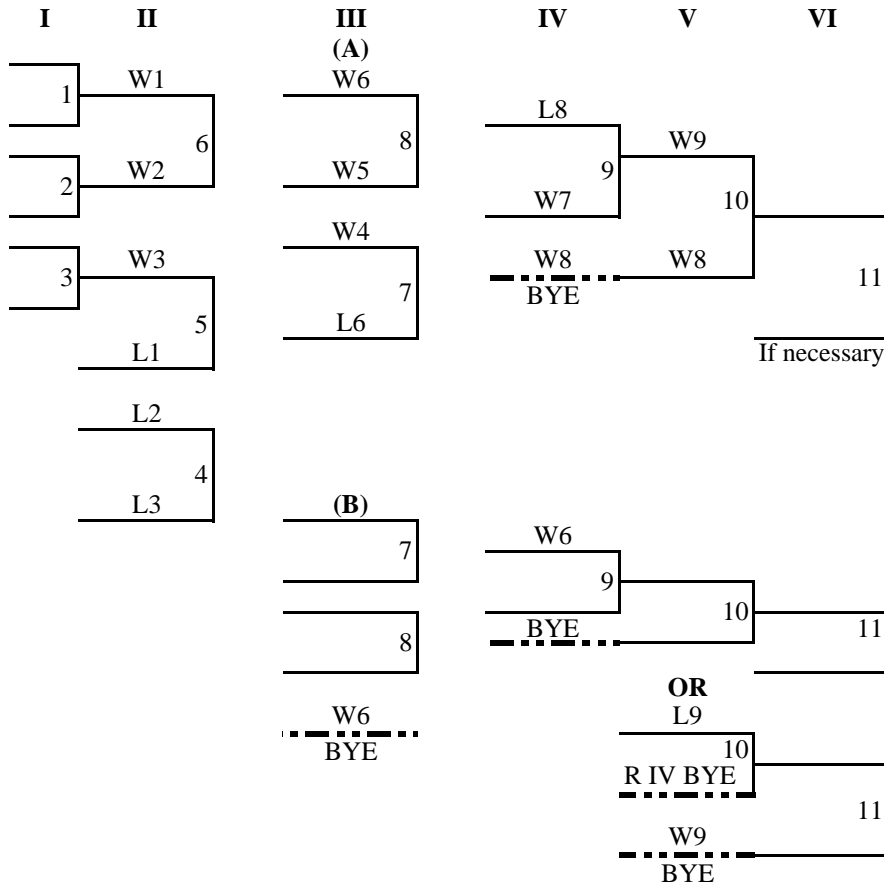

Round I: Draw for pairings.

Round II: L2 plays L3. W3 plays L1. W1 plays W2.

Note: After Round II, if W5 is undefeated, only 4 teams will remain. Use Bracket A. However, if W3 loses G5, there will be 5 teams remaining. Use Bracket B.

Bracket A Schedule:

Round III: L4 and L5 have been eliminated. W4 plays L6. W5 plays W6.

Round IV: L7 has been eliminated. Only 3 teams remain, 1 is undefeated with a (3-0) record. The undefeated team automatically receives the bye. L8 plays W7. Please refer to section P5-1v) for rules applicable to byes.

Round V: W9 plays W8.

Round VI: If necessary, there will be a sudden death championship game.

Bracket B Schedule:

Round III: L4 has been eliminated. 5 teams remain, 1 is undefeated. The undefeated team (W6) receives the bye. Match the 4 remaining teams, avoiding previous match-ups if possible. Where avoiding previous match-ups is not possible, a draw shall be held to determine pairings.

Round IV: L7 and L8 have been eliminated. 3 teams remain, 1 is undefeated. W7 and W8 draw for the bye. The draw loser plays W6.

Round V: 2 or 3 teams remain. If 2 teams remain, W9 plays the bye team. If 3 teams remain, W9 receives the bye and L9 plays the Round IV bye team.

Round VI: If necessary, there will be a sudden death championship game.

SCHEDULE TO BE FOLLOWED FOR A 7 TEAM TOURNAMENT

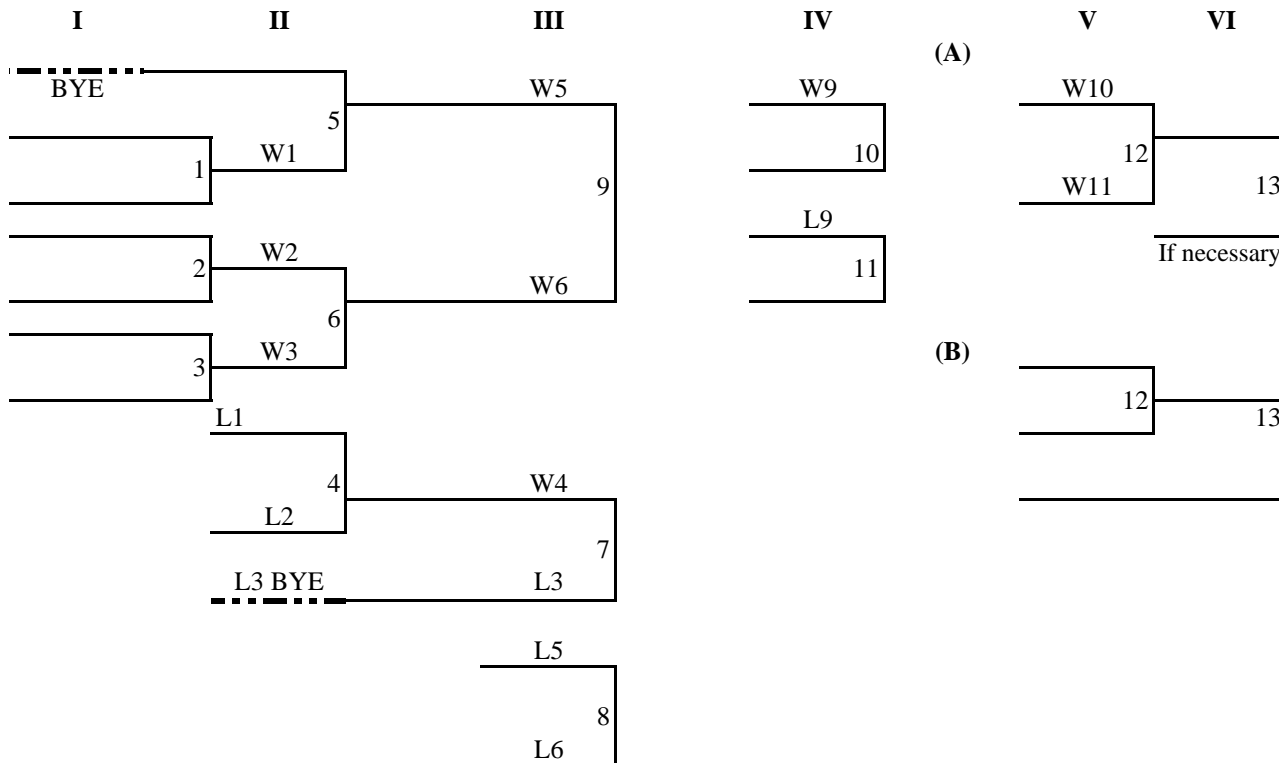

Round I:

Draw for bye and pairings. Please refer to section P5-1v) for rules applicable to byes.

Round II:

L1 plays L2. Round 1 bye team plays W1. W2 plays W3. L3 receives the bye.

Round III:

L4 has been eliminated. W4 plays L3. L5 plays L6. W5 plays W6.

Round IV:

L7 and L8 have been eliminated. At this point, 4 teams remain, 1 is undefeated. Match the 4 remaining teams, avoiding previous match-ups if possible. Where avoiding previous match-ups is not possible, a draw shall be held to determine pairings.

Note:

After Round IV, 2 or 3 teams remain. If 2 teams remain, use Bracket A. If 3 teams remain, use Bracket B.

Bracket A Schedule:

Round V:

W10 plays W11.

Round VI:

If necessary, there will be a sudden death championship game.

Bracket B Schedule:

Round V:

Draw for the bye if more than one team is eligible. The 2 remaining teams play each other.

Round VI:

This will be a sudden death championship game.

SCHEDULE TO BE FOLLOWED FOR AN 8 TEAM TOURNAMENT

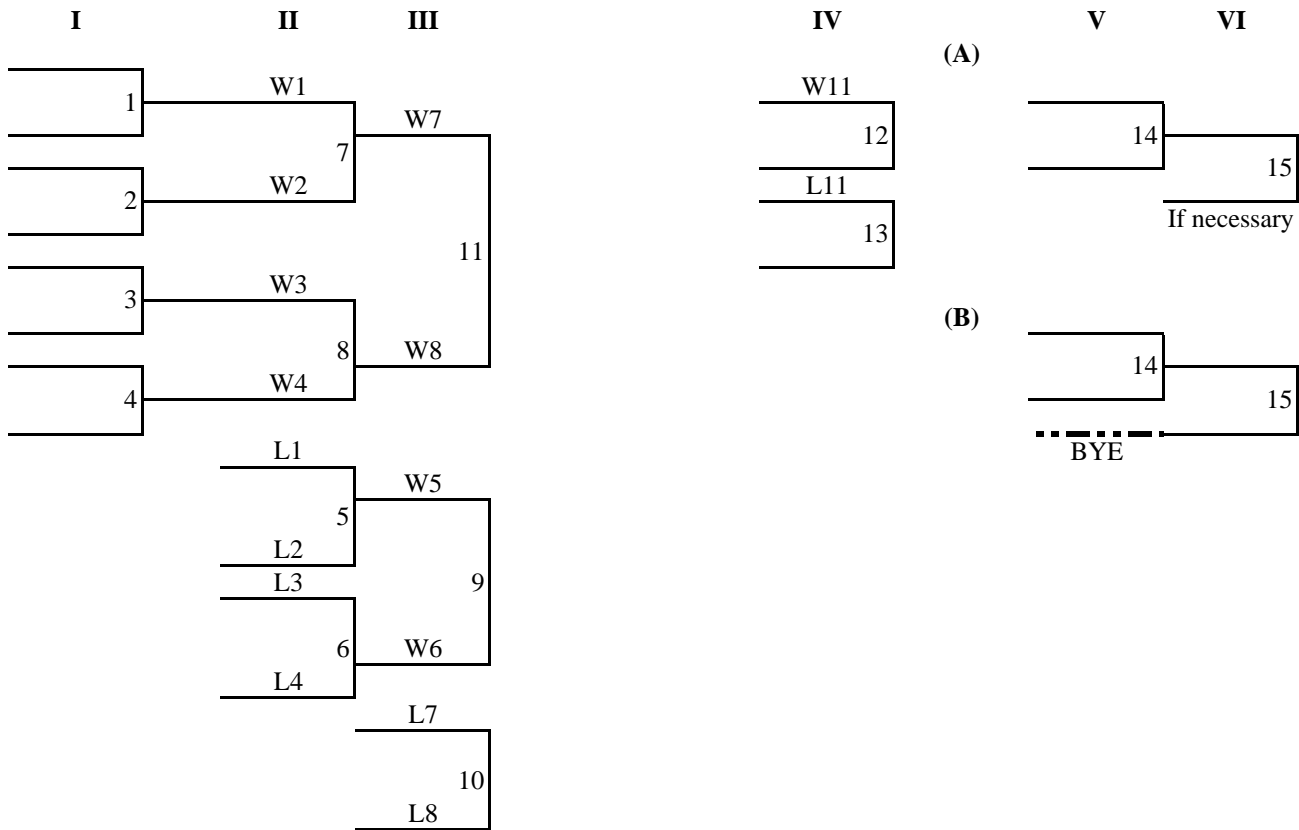

Round I: Draw for pairings.

Round II: L1 plays L2. L3 plays L4. W1 plays W2. W3 plays W4.

Round III: L5 and L6 have been eliminated. W5 plays W6. L7 plays L8. W7 plays W8.

Round IV: L9 and L10 have been eliminated. At this point, 4 teams remain, 1 is undefeated. Match the 4 remaining teams, avoiding previous match-ups if possible. Where avoiding previous match-ups is not possible, a draw shall be held to determine pairings.

Note: After Round IV, 2 or 3 teams remain. If 2 teams remain, use Bracket A. If 3 teams remain, use Bracket B

Bracket A Schedule:

Round V: W12 plays W13.

Round VI: If necessary, there will be a sudden death championship game.

Bracket B Schedule:

Round V: Draw for the bye among all teams. The 2 remaining teams will play each other. Please refer to section P5-1v) for rules applicable to byes.

Round VI: This will be a sudden death championship game.

SCHEDULE TO BE FOLLOWED FOR A 9 TEAM TOURNAMENT

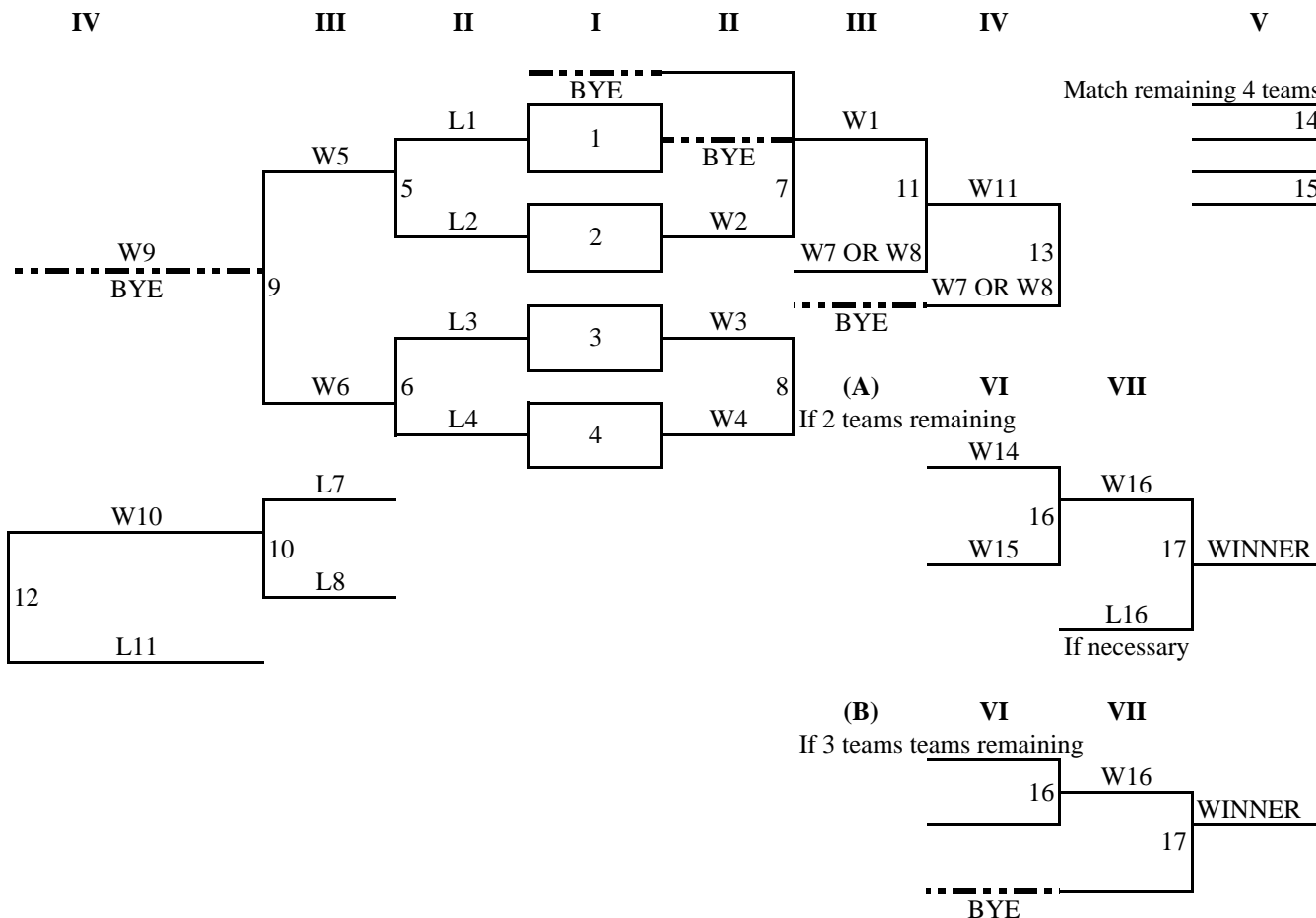

- Round I: Draw for pairings. First team drawn receives the bye.
- Round II: L1 plays L2. L3 plays L4. W1 receives Round II bye. Round I bye team plays W2. W3 plays W4.
- Round III: L5 and L6 have been eliminated. W5 plays W6. L7 plays L8.
- Note: If W2 is W7, they receive the bye in Round III and W1 plays W8. However, if W2 loses G7, W8 receives the bye and W1 plays W7.
- Round IV: L9 and L10 have been eliminated. W9 receives the bye. W10 plays L11. W11 plays the Round III bye team.
- Round V: L12 has been eliminated. At this point, 4 teams remain, 1 is undefeated. Match the 4 remaining teams, avoiding previous match-ups if possible. Where avoiding previous match-ups is not possible, a draw shall be held to determine pairings.
- Round VI: 2 or 3 teams remain. If 2 teams remain, use Bracket A. If 3 teams remain, use Bracket B.
- Bracket A Schedule:**
- Round VI: W14 plays W15.
- Round VII: If necessary. W16 plays L16.
- Bracket B Schedule:**
- Round VI: Draw for the bye if necessary. Please refer to section P5-1) for rules applicable to byes.
- Round VII: L16 has been eliminated. W16 plays bye team. Sudden death game.

SCHEDULE TO BE FOLLOWED FOR A 10 TEAM TOURNAMENT

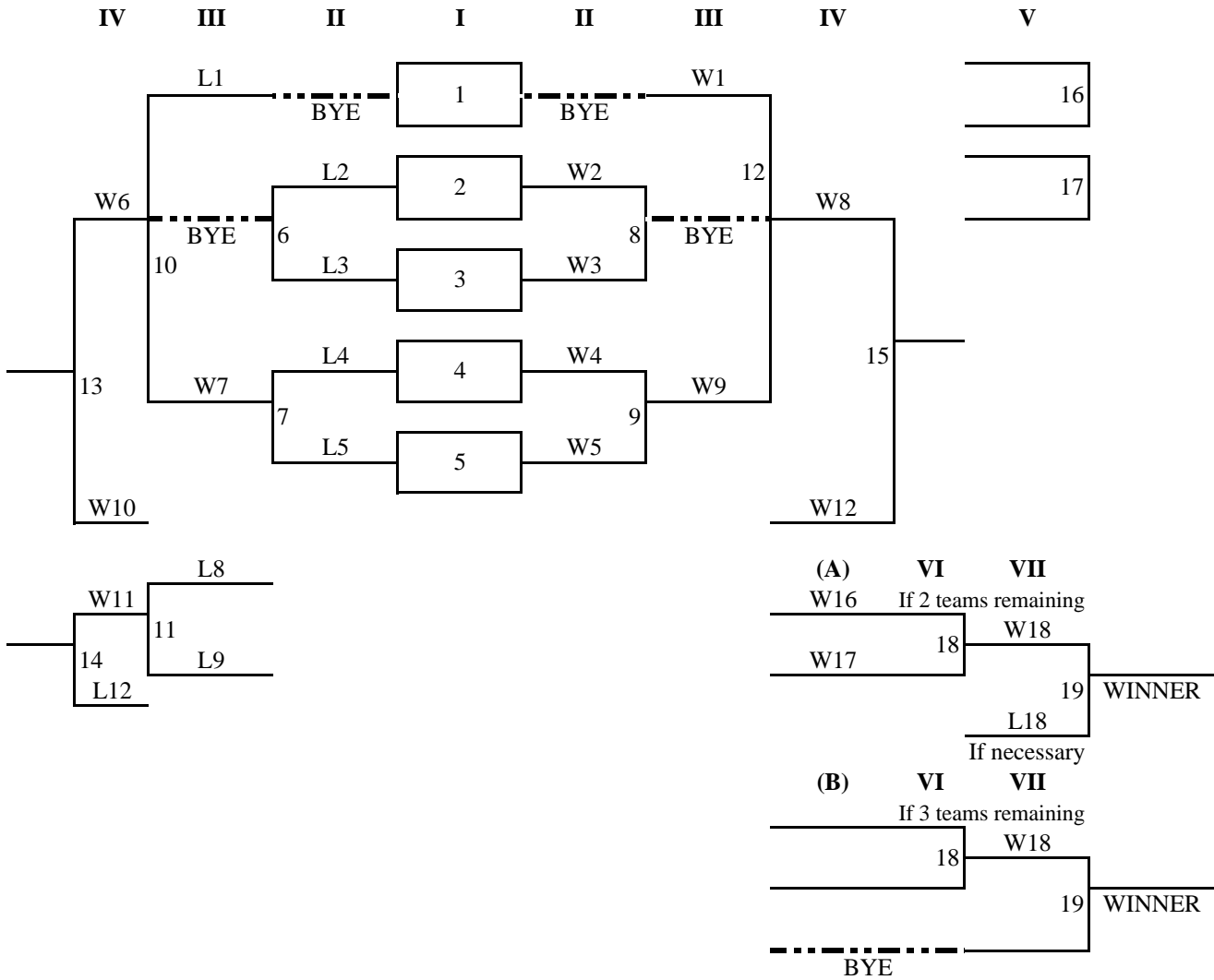

Round I: Draw for pairings.

Round II: W1 receives the bye. W2 plays W3. W4 plays W5. L1 receives the bye. L2 plays L3. L4 plays L5.

Round III: L6 and L7 have been eliminated. W6 receives the bye. L1 plays W7. L8 plays L9. W8 receives the bye. W1 plays W9.

Round IV: L10 and L11 have been eliminated. W6 plays W10. W11 plays L12. W8 plays W12.

Round V: L13 and L14 have been eliminated. 4 teams remain, 1 undefeated. Match teams, avoiding previous match-ups where possible. Where avoiding previous match-ups is not possible, a draw shall be held to determine pairings.

Round VI: 2 or 3 teams remain. If 2 teams remain, 1 will be undefeated. Use Bracket A. If 3 teams remain, draw for the bye if necessary. Use Bracket B. Please refer to section P5-1v) for rules applicable to byes.

Round VII: If necessary, there will be a sudden death championship game.

SCHEDULE TO BE FOLLOWED FOR AN 11 TEAM TOURNAMENT

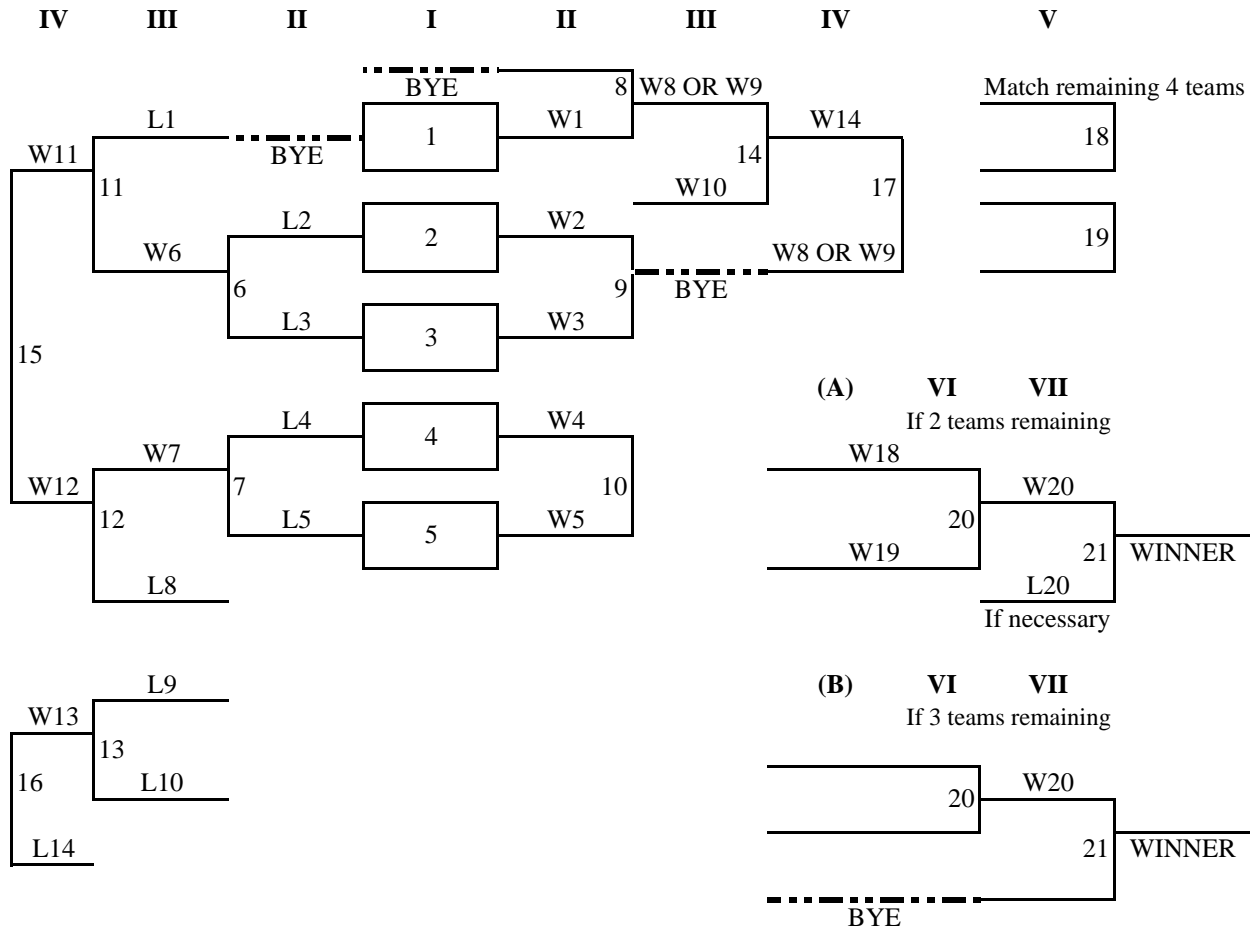

- Round I: Draw for pairings. First team drawn receives the bye.
- Round II: L1 receives the bye. L2 plays L3. L4 plays L5. Round I bye team plays W1. W2 plays W3. W4 plays W5.
- Round III: L6 and L7 have been eliminated. L1 plays W6. W7 plays L8. L9 plays L10.
 Note: If W8 is (2-0), they receive the bye. W9 plays the winner of G10. If W8 has had a bye, W8 plays W10 and W9
- Round IV: L11, L12 and L13 have been eliminated. W11 plays W12. W13 plays L14. W14 plays the Round III bye team.
- Round V: L15 and L16 have been eliminated. Only 4 teams remain, 1 undefeated. Match teams, avoiding previous match-ups where possible. Where avoiding previous match-ups is not possible, a draw shall be held to determine pairings.
- Round VI: 2 or 3 teams remain. If 2 teams remain, use Bracket A. If 3 teams remain, draw for the bye if necessary. Use Bracket B. Please refer to section P5-1v) for rules applicable to byes.
- Round VII: If necessary, there will be a sudden death championship game.

SCHEDULE TO BE FOLLOWED FOR A 12 TEAM TOURNAMENT

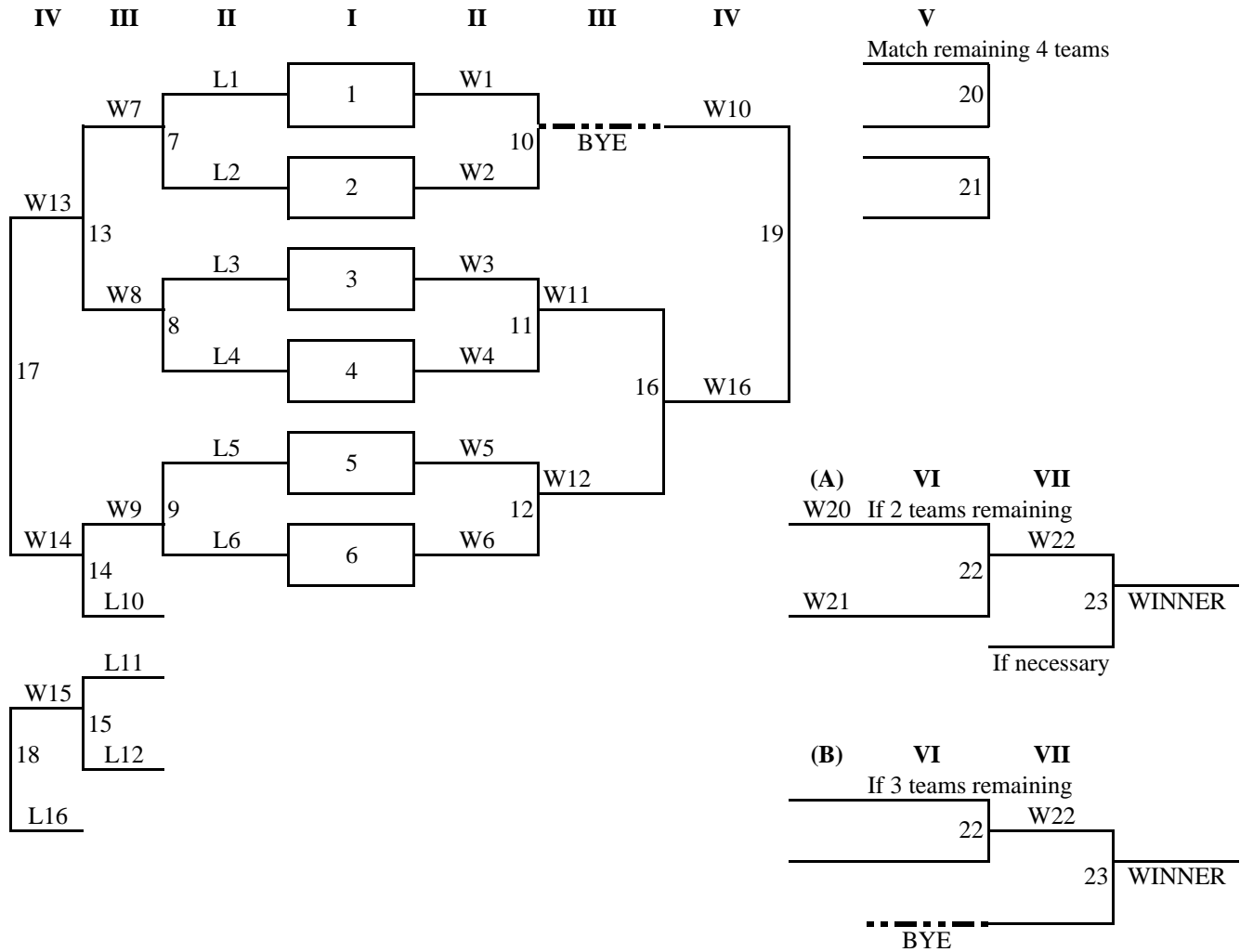

- Round I: Draw for pairings.
- Round II: L1 plays L2. L3 plays L4. L5 plays L6. W1 plays W2. W3 plays W4. W5 plays W6.
- Round III: L7, L8, and L9 have been eliminated. W7 plays W8. W9 plays L10. L11 plays L12. W10 receives the bye. W11 plays W12.
- Round IV: L13, L14 and L15 have been eliminated. W13 plays W14. W15 plays L16. W16 plays W10.
- Round V: L17 and L18 have been eliminated. 4 teams remain, 1 undefeated. Match teams, avoiding previous match-ups where possible. Where avoiding previous match-ups is not possible, a draw shall be held to determine pairings.
- Round VI: 2 or 3 teams remain. If 2 teams remain, use Bracket A. If 3 teams remain, draw for the bye if necessary. Use Bracket B. Please refer to section P5-1v) for rules applicable to byes.
- Round VII: If necessary, there will be a sudden death championship game.

SCHEDULE TO BE FOLLOWED FOR A 13 TEAM TOURNAMENT

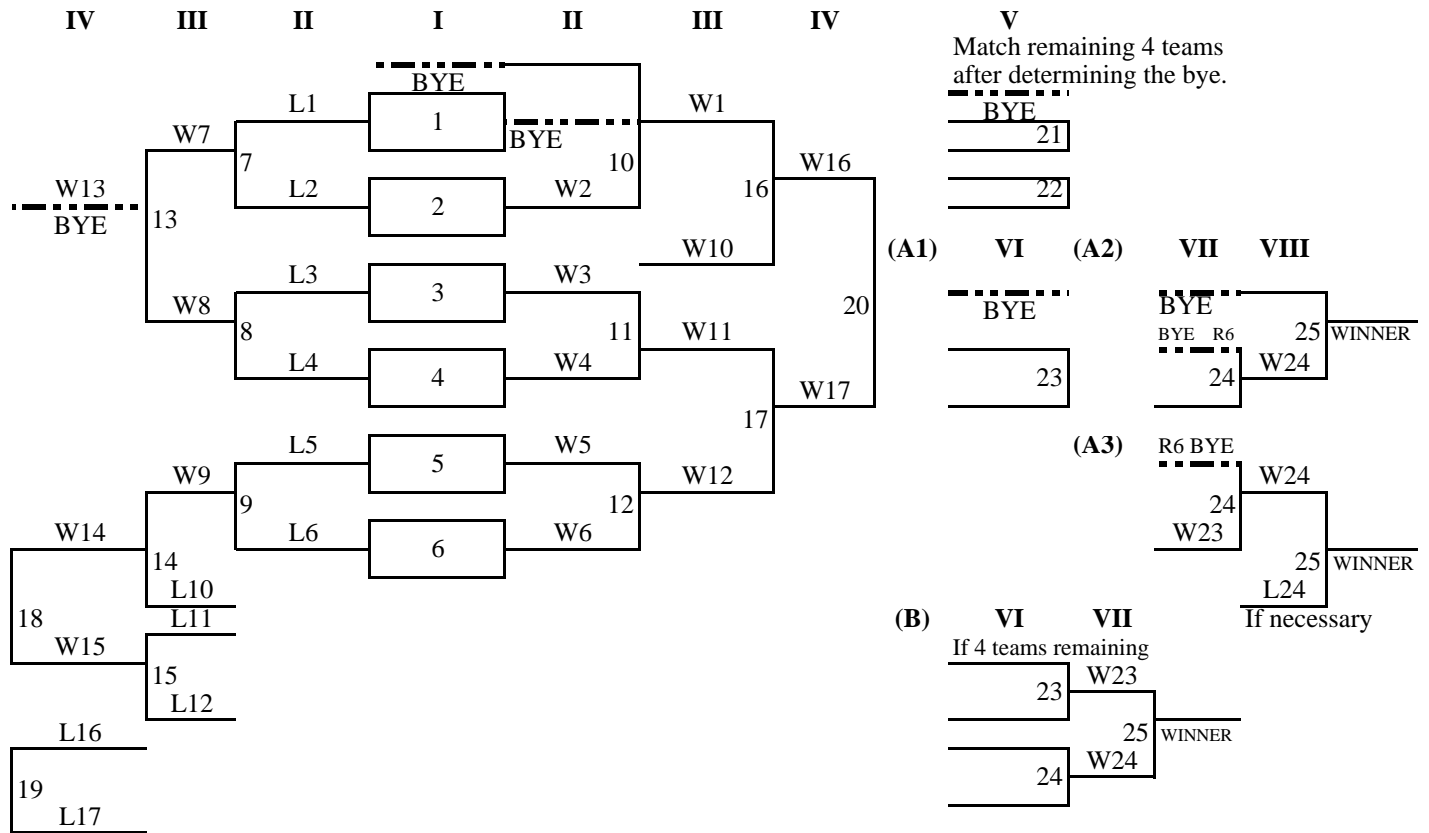

Round I: Draw for pairings. First team drawn receives the bye.
 Round II: L1 plays L2. L3 plays L4. L5 plays L6. W1 receives the bye. Round I bye team plays W2. W3 plays W4. W5 plays W6.
 Round III: L7, L8 and L9 have been eliminated. W7 plays W8. W9 plays L10. L11 plays L12. W1 plays W10. W11 plays W12.
 Round IV: L13, L14 and L15 have been eliminated. W13 receives the bye. W14 plays W15. L16 plays L17. W16 plays W17.
 Round V: L18 and L19 have been eliminated. At this point, 5 teams remain, 1 is undefeated. If the undefeated team is (4-0), they receive the bye. However, if the undefeated team is (3-0), draw for the bye from the teams that have not already had one. In either case, match the 4 remaining teams, avoiding previous match-ups where possible. Where avoiding previous match-ups is not possible, a draw shall be held to determine pairings. Please refer to section P5-1v) for rules applicable to byes.

Round VI: Note: 3 or 4 teams remain. If 3 teams remain, use Bracket A1. If 4 teams remain, use Bracket B.

Bracket A1 Schedule:

Round VI: Draw for the bye if necessary. Remaining team plays RV bye in game 23.
 Round VII: If 3 teams remain use A2. Draw for bye. Remaining team plays bye RV1.
 If 2 teams remain use A3. W23 plays RVI bye.
 Round VIII: A2. W24 plays RVII bye
 A3. W24 plays L24. If necessary.

Bracket B Schedule:

Round VI: Match remaining 4 teams, avoiding previous match-ups where possible. Where avoiding previous match-ups is not possible, a draw shall be held to determine pairings.
 Round VII: W23 plays W24.

SCHEDULE TO BE FOLLOWED FOR A 14 TEAM TOURNAMENT

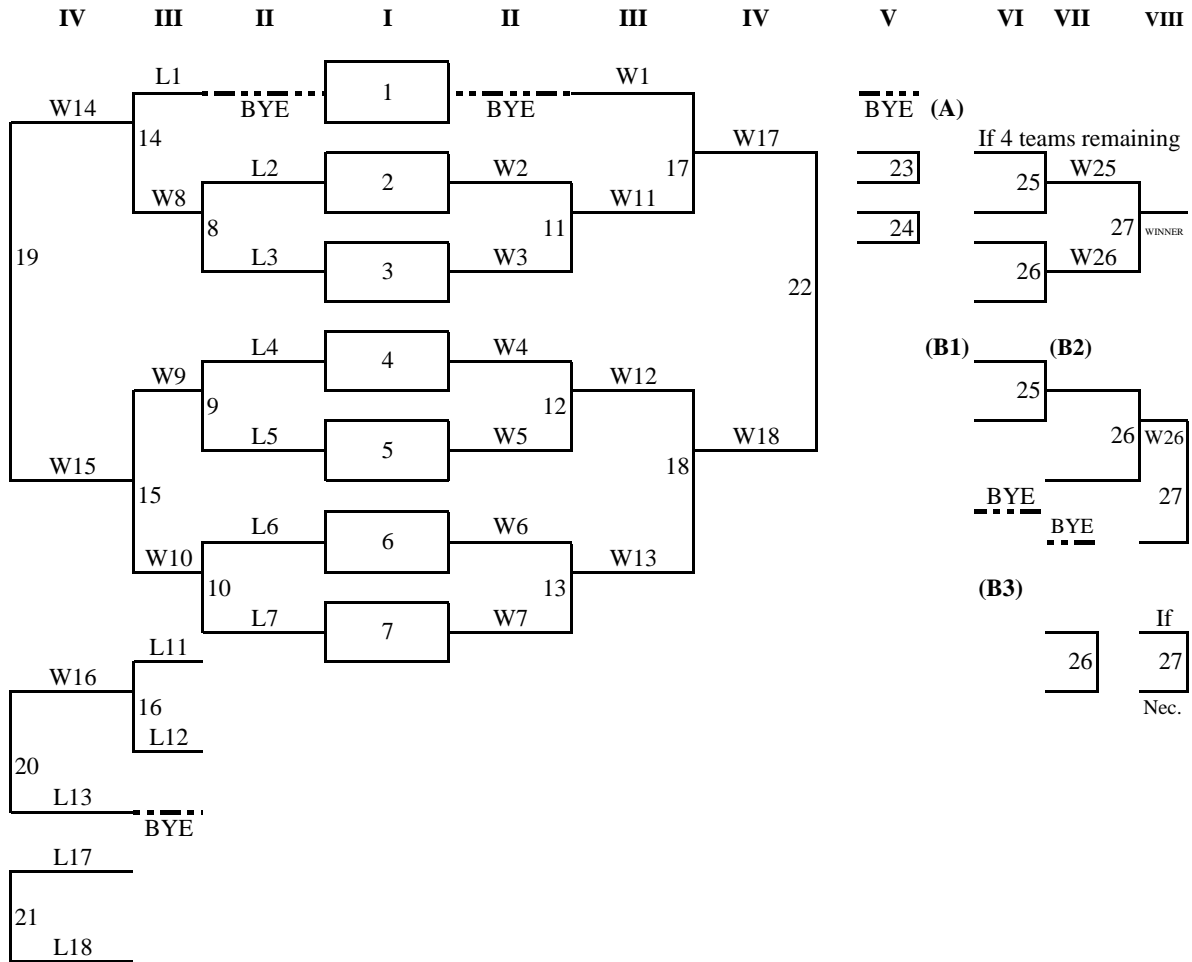

- ROUND I: Draw for pairings.
- ROUND II: Loser 2 vs. loser 3, loser 4 vs. loser 5, loser 6 vs. loser 7, winner 2 vs. winner 3, winner 4 vs. winner 5, winner 6 vs. winner 7. Loser of 1 and winner of 1 receive round 2 byes.
- ROUND III: Losers of games 8, 9 & 10 have been eliminated. Loser 1 vs. winner 8, winner 9 vs. winner 10, loser of 11 vs. loser 12, winner 1 vs. winner 11, winner 12 vs. winner 13. Loser of game 13 receives a bye.
- ROUND IV: Losers of games 14, 15 & 16 have been eliminated. Winner 14 vs. winner 15, winner 16 vs. loser 13, loser 17 vs. loser 18, winner 17 vs. winner 18.
- ROUND V: Losers of games 19, 20, & 21 have been eliminated. Five teams remain, one undefeated. If the undefeated team is (4-0), they receive the bye. Otherwise, draw for the bye from amongst the teams that have not had one. Match the four remaining teams, avoiding previous match-ups if possible. Where avoiding previous match-ups is not possible, a draw shall be held to determine pairings. Please refer to section P5-1v) for rules applicable to byes.

ROUND VI: Three or 4 teams remain. If 3 use bracket B1. If four use Bracket A.

Bracket A Schedule

(ROUND VI): Four teams remain, all will have a loss. Match teams, avoiding previous match-ups if possible. Where avoiding previous match-ups is not possible, a draw shall be held to determine pairings.

(ROUND VII:) W25 Plays W26.

Bracket B1 Schedule: 3 Teams remain 1 undefeated.

(ROUND VI): Draw for the bye if necessary. Remaining team play RV bye team in game 25.

(ROUND VII:) 2 or 3 Teams remain. If 3 use B2. If 2 use B3.

Bracket B2 Schedule: 3 Teams remain.

(ROUND VII:) Draw for bye if necessary. Remaining team play R6 bye team in game 26.

(ROUND VIII:) W26 plays R VII bye team.

Bracket B3 Schedule: 2 Teams remain.

(ROUND VII:) W25 plays RVI bye team.

(ROUND VIII:) W26 plays L26. If necessary.

SCHEDULE TO BE FOLLOWED FOR A 15 TEAM TOURNAMENT

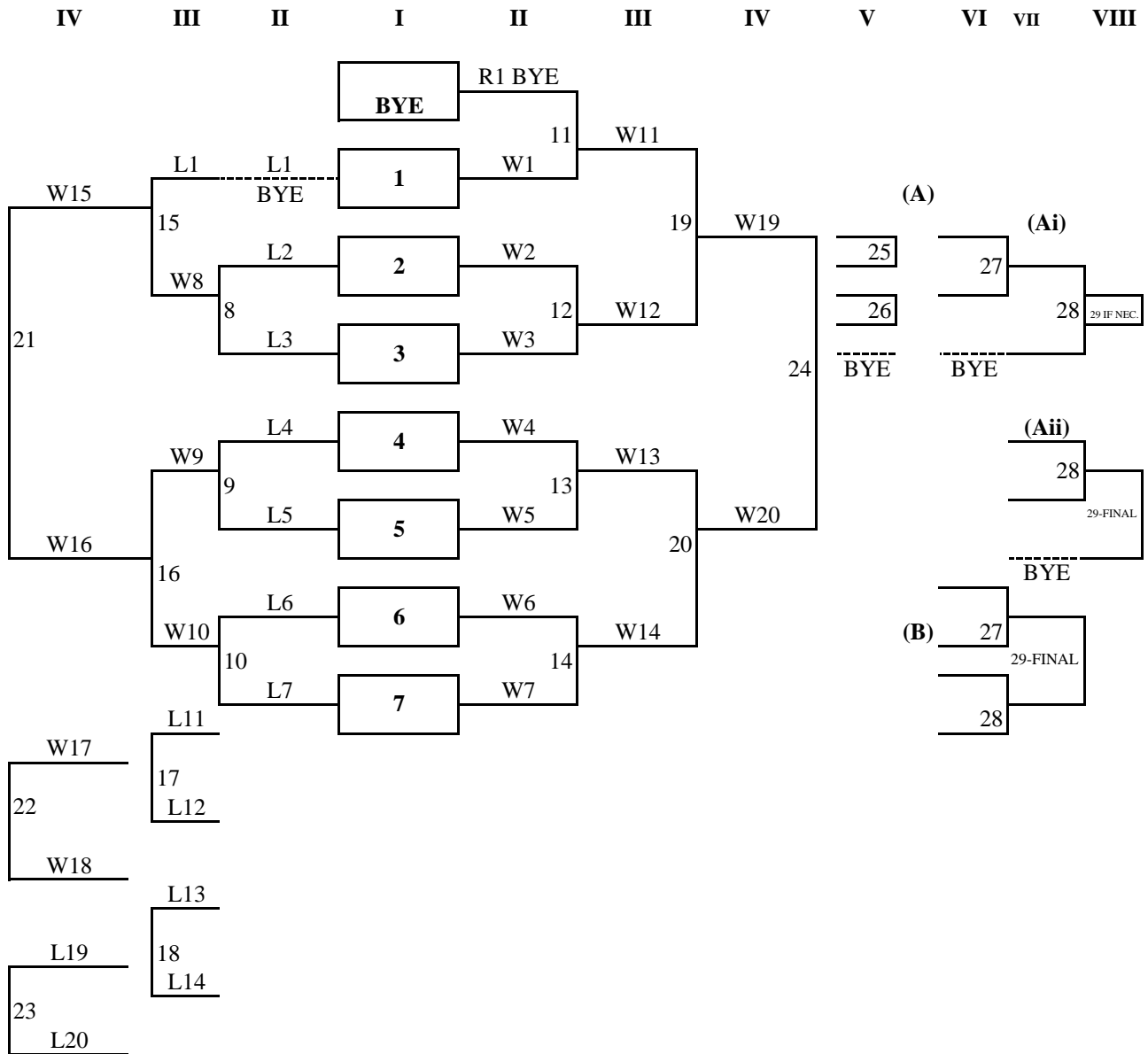

- ROUND I: Draw for pairings games one through seven. The first team drawn receives Round 1 Bye.
- ROUND II: Loser of Game #1 receives Bye in round 2. L2 plays L3, L4 plays L5, L6 plays L7. W1 plays Bye 1, W2 plays W3, W4 plays W5, W6 plays W7.
- ROUND III: Loser of games 8, 9 and 10 have been eliminated. W8 plays L1, W9 plays W10, L11 plays L12, L13 plays L14, W11 plays W12, W13 plays W14.
- ROUND IV: Losers of games 15, 16, 17 and 18 have been eliminated. W15 plays W16, W17 plays W18, L19 plays L20. W19 plays W20.
- ROUND V: Five teams remain, one team is undefeated. If the undefeated team is 4-0, they receive the bye. Please refer to section P5-1v) for rules applicable to byes. Otherwise, draw for the bye. Pair teams, avoiding previous match-ups where possible.
- ROUND VI: If the undefeated team has the Bye in Round 5, 3 teams remain. Use Bracket "A". Note: if the undefeated team lost in Round 5, use Bracket "B". In this case four teams remain and all have a loss.
- ROUND VII: If after Round 6 in "A" Bracket there is still an undefeated team, 2 teams remain. Use Bracket "(Ai)". If after Round 6 in "A" Bracket 3 teams still remain, use Bracket "(Aii)". Draw for bye if necessary. In "B" Bracket, W27 plays W28 for championship.
- ROUND VIII: This round is possible only in "A" Brackets. In Bracket (Ai), game 29 is necessary if the undefeated team lose in game 28. In Bracket (Aii), W28 plays Round 7 Bye team for championship in game 29.

SCHEDULE TO BE FOLLOWED FOR A 16 TEAM TOURNAMENT

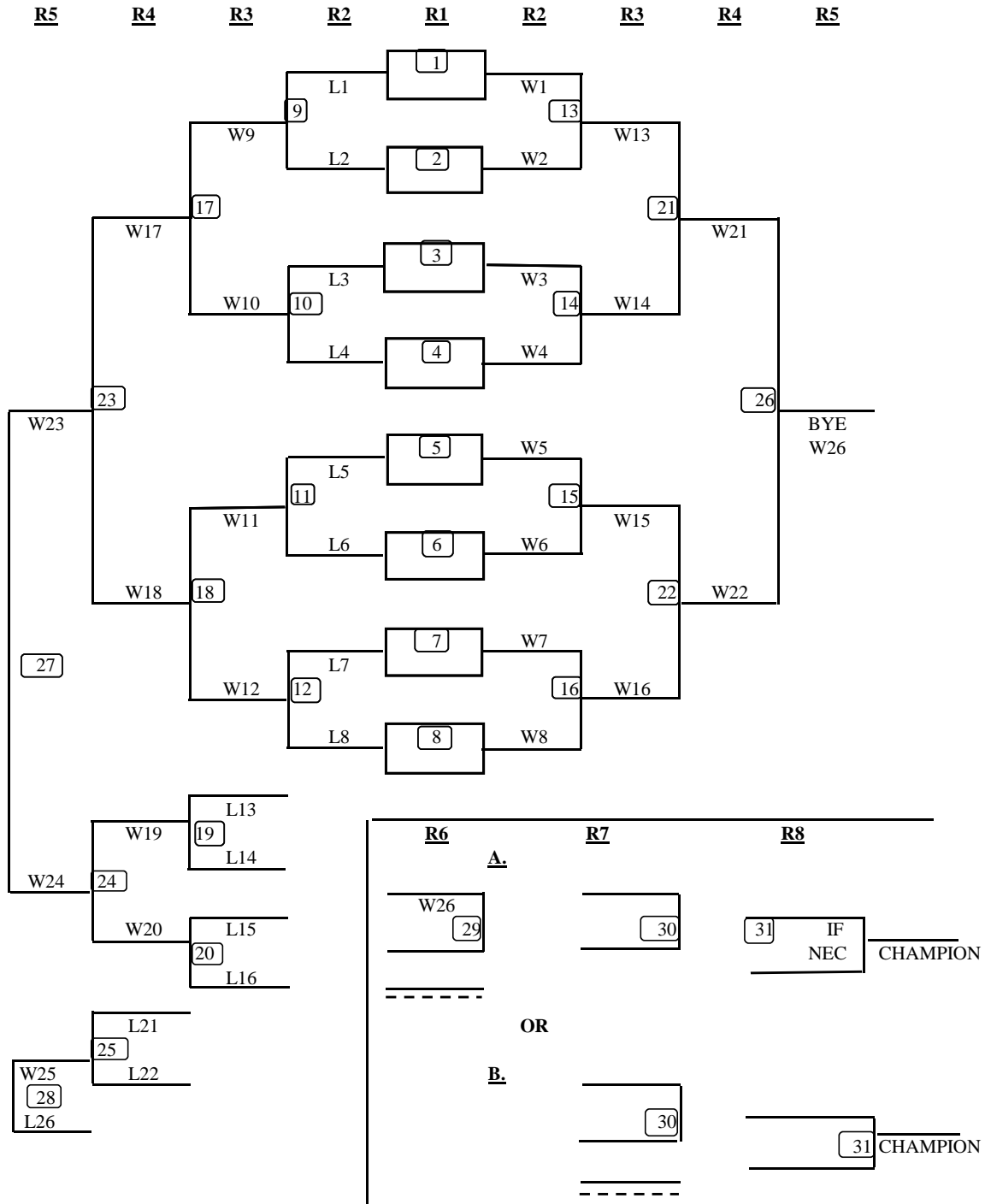

Round 1 Draw for pairings games one through 8

Round 2 L1 plays L2, L3 plays L4, L5 plays L6, L7 Plays L8, W1 plays W2, W3 plays W4, W5 plays W6, W7 plays W8.

Round 3 Losers of games 9, 10, 11 and 12 have been eliminated. W9 plays W 10, W11 plays W12, L13 plays L14, L15 plays L16, W13 plays W14, W15 plays W16

Round 4 Losers of games 17, 18, 19 and 20 have been eliminated. W17 plays W18, W19 plays W20, L21 plays L22, W21 plays W22

Round 6 Losers of Games 27 and 28 have been eliminated. 3 teams remain. W26 must play. Draw for bye between W27 and W28 to see who plays W26 in game #29.

After Round 6, two or three teams remain. If two remain, one is undefeated. Use Bracket A. If three remain, all have one loss, use Bracket B.

Bracket A Two remaining teams play in round 7. If undefeated team loses game # 30, same two teams play again in game 31 in round 8 for Championship.

Bracket B
Round 8 - W30 plays bye team from Round 7 for Championship.

SCHEDULE TO BE FOLLOWED FOR A 17 TEAM TOURNAMENT

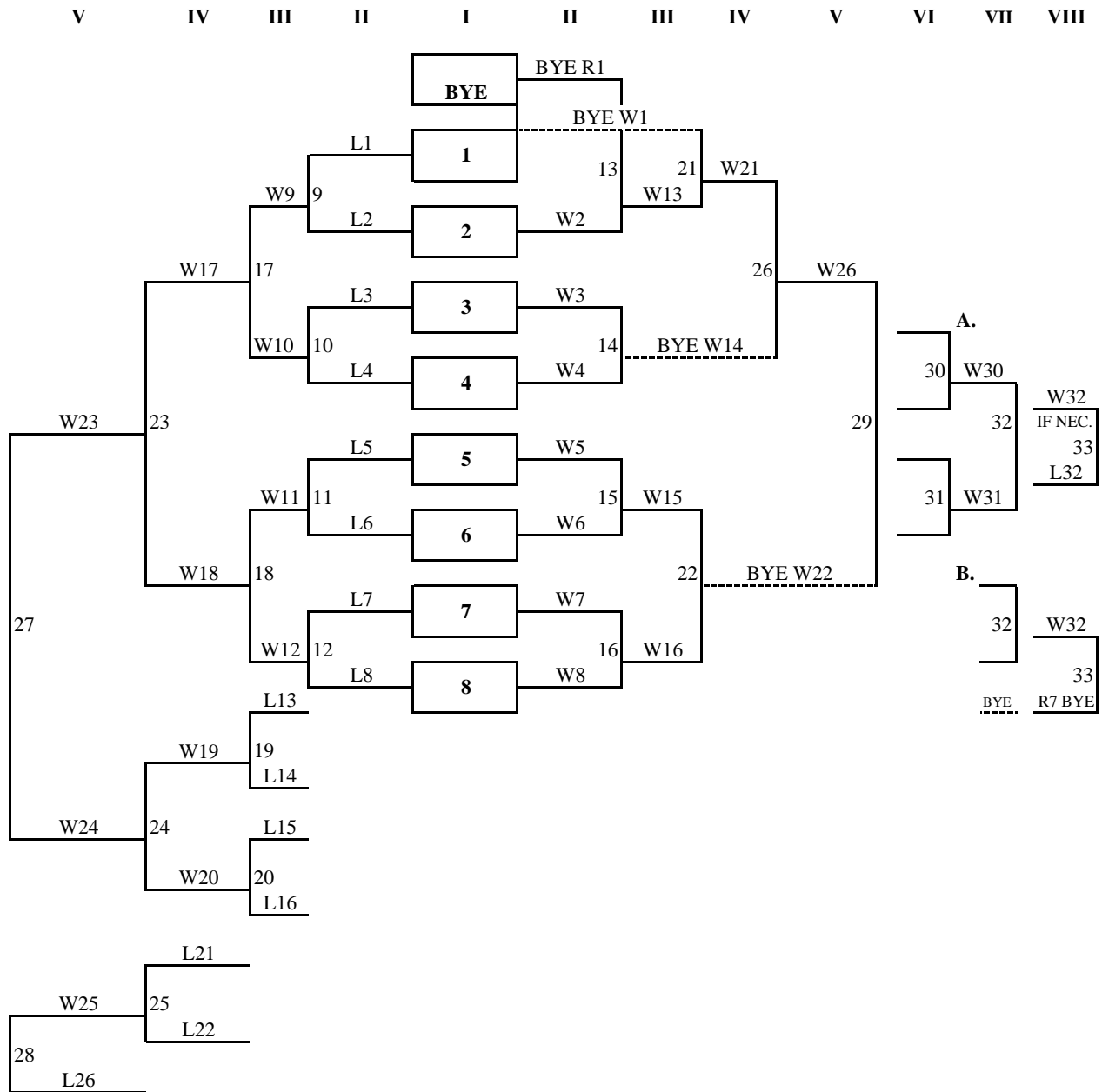

- ROUND I: First team drawn receives the bye. Draw for pairings of games one through eight.
- ROUND II: L1 vs L2, L3 vs L4, L5 vs L6, L7 vs L8. Winner of game 1 receives a bye. Winner of game 2 vs first round bye team, W3 vs W4, W5 vs W6, W7 vs W8.
- ROUND III: Loser of games 9, 10, 11, and 12 have been eliminated. W9 vs W10, W11 vs W12, L13 vs L14, L15 vs L16. Note: winner of game 14 draws bye. W1 vs W13, W15 vs W16.
- ROUND IV: Loser of games 17, 18, 19 and 20 have been eliminated. W17 vs W18, W19 vs W20, L21 vs L22, W21 vs W14. Note: winner of game 22 receives a bye.
- ROUND V: Loser of games 23, 24 and 25 have been eliminated. W23 vs W24, W25 vs L26, W26 vs W22.
- ROUND VI: Loser of games 27 and 28 have been eliminated. Note: only four teams remain, one undefeated. Draw or pair remaining four teams, avoiding previous match-ups where possible.
- ROUND VII: Only two or three teams remain. If two, one is undefeated. Use Bracket "A". If three teams remain, draw for the bye amongst the teams that have not previously had one. Please refer to section P5-1v) for rules applicable to
- ROUND VIII: Bracket "A": W32 vs L32, if necessary. Bracket "B": W32 vs R7 Bye.

SCHEDULE TO BE FOLLOWED FOR A 18 TEAM TOURNAMENT

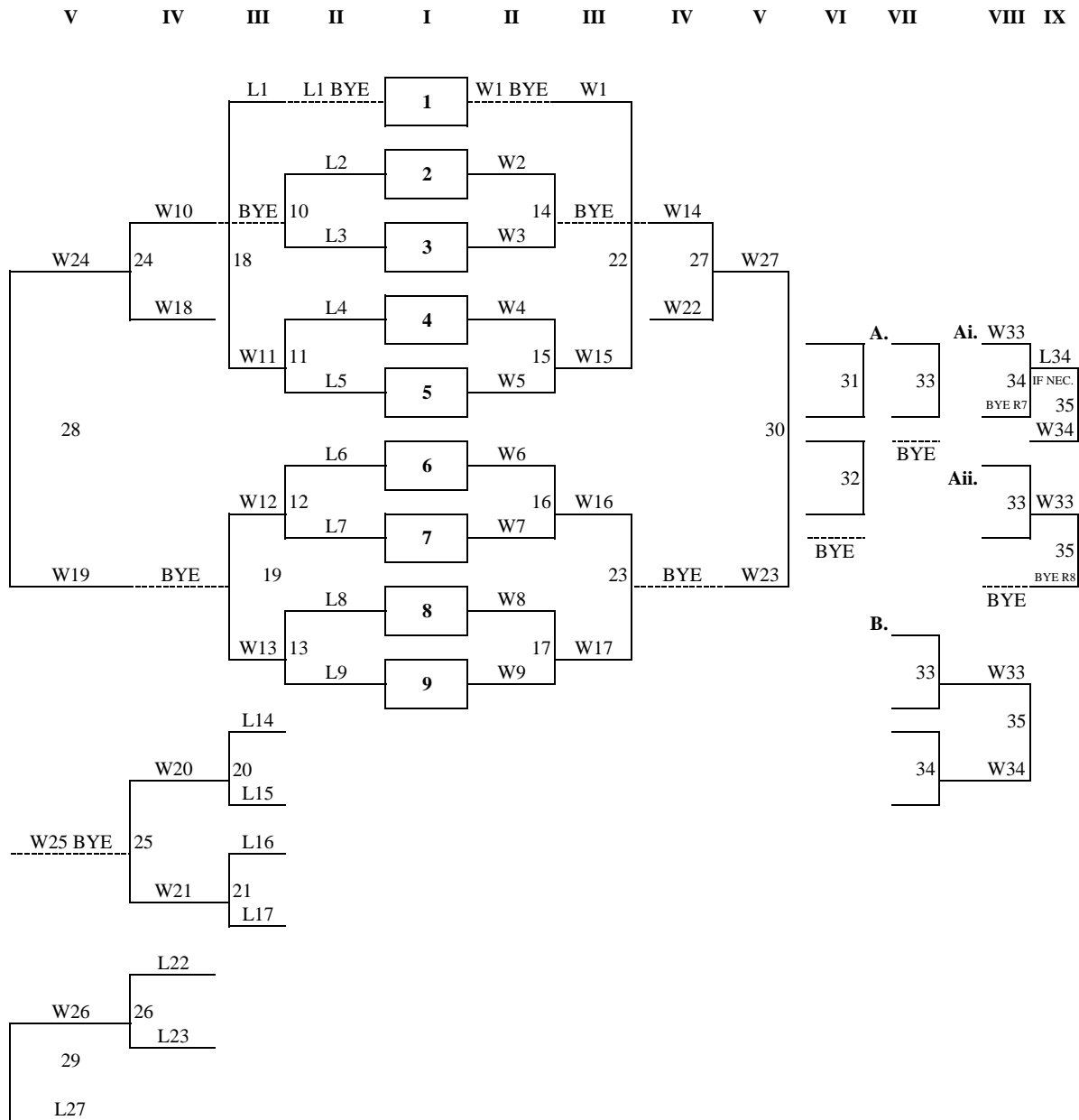

ROUND I: Draw for pairings.

ROUND II: Loser of game #1 and winner of game #1 receive byes. L2 vs L3, L4 vs L5, L6 vs L7, L8 vs L9. W2 vs W3, W4 vs W5, W6 vs W7, W8 vs W9.

ROUND III: Loser of games 10, 11, 12 and 13 have been eliminated. Winner of game 10 receives a bye. L1 vs W11, W12 vs W13, L14 vs L15, L16 vs L17. Winner of game 14 receives a bye. W1 vs W15, W16 vs W17.

ROUND IV: Loser of games 18, 19, 20 and 21 have been eliminated. Winner of game 19 receives a bye. W10 vs W18, W20 vs W21, L22 vs L23. Winner of game 23 receives a bye. W14 vs W22.

ROUND V: Loser of game 24, 25 and 26 have been eliminated. Winner of game 25 receives a bye. W24 vs W19, W26 vs L27, W27 vs W23.

ROUND VI: Loser of games 28 and 29 have been eliminated. Five teams remain, one is undefeated. Note: if the undefeated team is 5 and 0, they receive the bye. Otherwise, draw for the bye and avoid previous match-ups if possible. Please refer to section P5-1v) for rules applicable to byes. A draw may be required to determine pairings.

ROUND VII: Three or four teams remain. If three teams, use Bracket "A". Draw for the bye if necessary. If four teams remain, use Bracket "B". Avoid previous pairings if possible. Otherwise, draw for pairings.

ROUND VIII: Two or three teams remain. From Bracket "A", if 2 are left, one is undefeated. Use Bracket "Ai". If three teams remain, use Bracket "Aii". Draw for bye among eligible teams. From Bracket "B" W33 plays W34.

ROUND IX: Two teams remain. From Bracket "Ai" L34 plays W34 if necessary. From Bracket "Aii" W34 plays Round 8 bye.

SCHEDULE TO BE FOLLOWED FOR A 19 TEAM TOURNAMENT

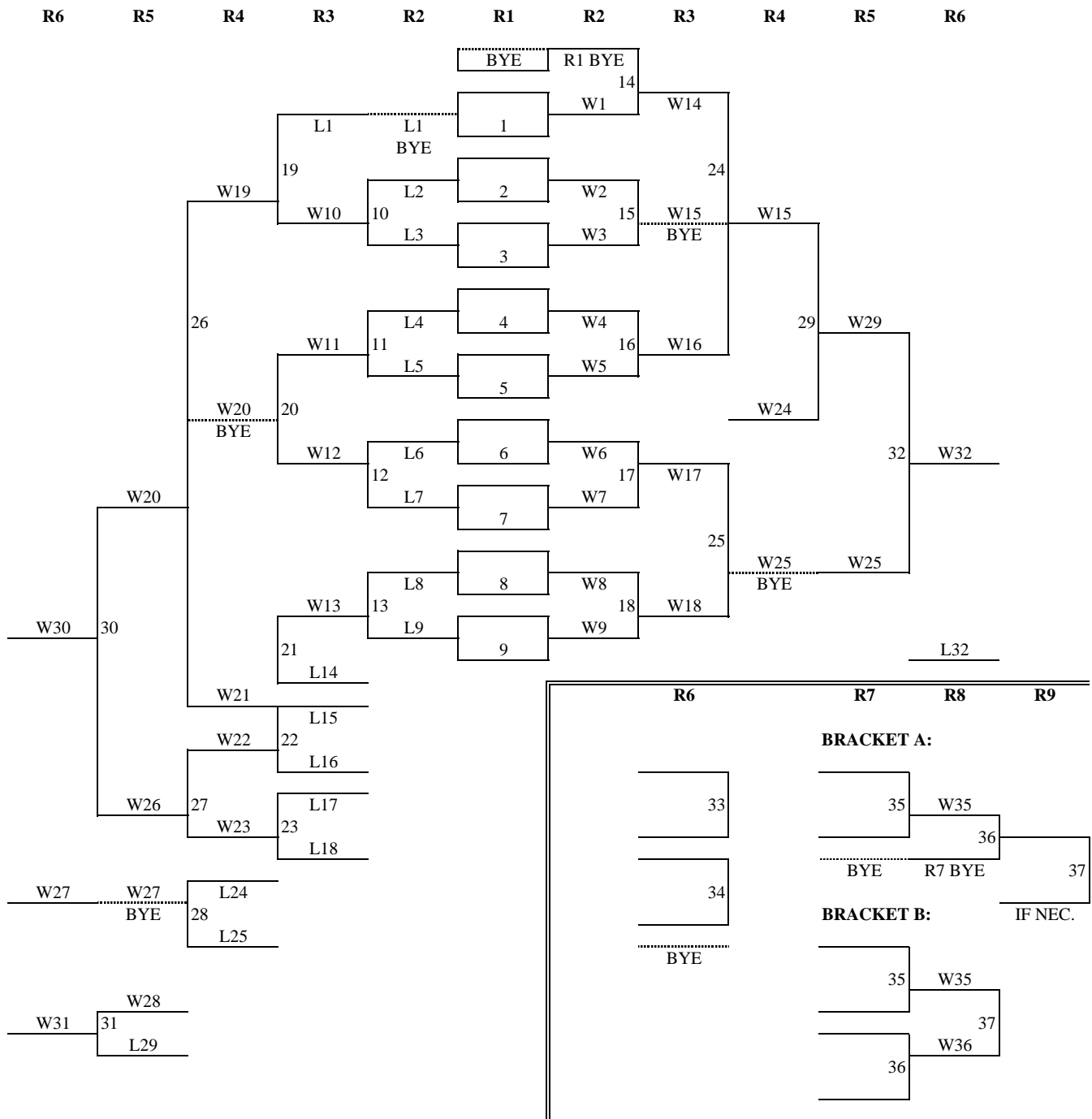

ROUND 1:

First team drawn receives the bye. Draw for pairings games one through nine.

ROUND 2:

Loser of game # 1 receives the bye. L2 vs. L3, L4 vs. L5, L6 vs. L7, L8 vs. L9. First round bye team vs. W1, W2 vs. W3, W4 vs. W5, W6 vs. W7, W8 vs. W9.

ROUND 3:

Losers of games # 10, 11, 12 and 13 have been eliminated. L1 vs. W10, W11 vs. W12, W13 vs. L14, L15 vs. L 16, L17 vs. L18, W14 vs. W16, W17 vs. Winner game #15 receives a bye.

ROUND 4:

Losers of games # 19, 20, 21, 22 and 23 have been eliminated. W19 vs. W21, W22 vs. W23, L24 vs. L25. Winner of game #20 receives a bye. W15 vs. Winner of game #25 receives a bye.

ROUND 5:

Losers of games # 26, 27 and 28 have been eliminated. W20 vs. W26, W28 vs. L29. Winner of game # 27 receives a bye. W29 vs. W25.

ROUND 6:

Losers of games # 30 and 31 have been eliminated. Only 5 teams remain. One is undefeated. If the undefeated team is 5 and 0, they automatically receive the bye, otherwise, draw for the bye. Please refer to section P5-1v) for rules applicable to byes. Pair remaining teams, avoiding previous matchups where possible. Note: if all five remaining teams have had a bye and the undefeated team is 4 and 0, the undefeated team would receive the bye.

ROUND 7:

Three or four teams remain. If three teams, use Bracket "A". Draw for the bye if necessary. If four teams remain, all have one loss. Use bracket "B". Draw or pair teams avoiding previous matchups if possible.

ROUND 8:

Two teams remain. One may be undefeated.

ROUND 9:

If necessary.

SCHEDULE TO BE FOLLOWED FOR A 20 TEAM TOURNAMENT

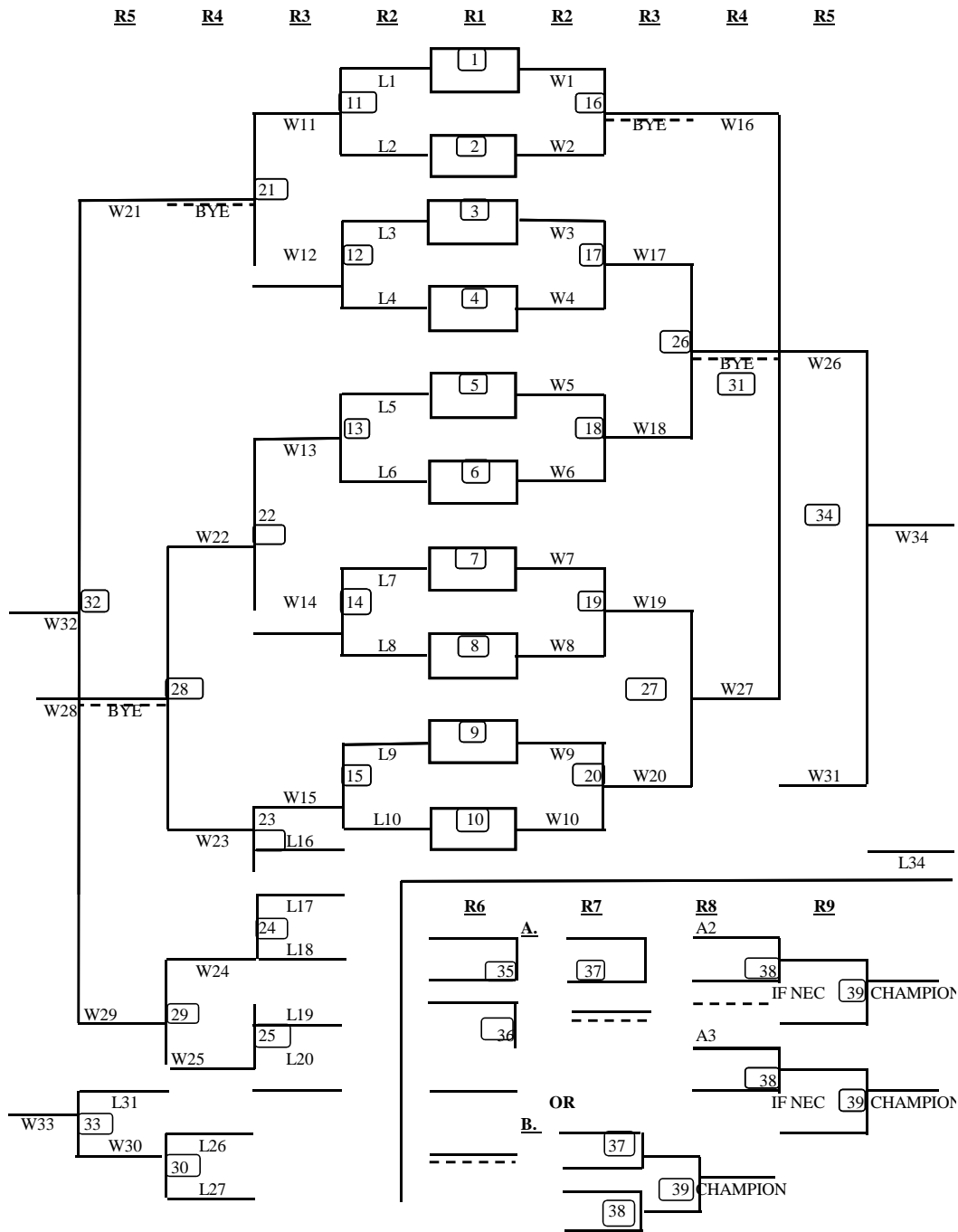

Round 1 Draw for pairings games 1 through 10.

Round 2 L1 plays L2, L3 plays L4, L5 plays L6, L7 plays L8, L9 plays L10, W1 plays W2, W3 plays W4, W5 plays W6, W7 plays W8, W9 plays W10.

Round 3 Losers of games 11, 12, 13, 14 and 15 have been eliminated. W11 plays W12, W13 plays W14, W15 plays L16, L17 plays L18, L19 plays L20. Winner of game #16 receives a bye. W17 plays W18, W19 plays W20.

Round 4 Losers of games 21, 22, 23, 24 and 25 have been eliminated. Winner of game #21 receives a bye. W22 plays W23, W24 plays W25, L26 plays L27, W16 plays W27. Winner of game #26 receives a bye.

Round 5 Losers of games 28, 29 and 30 have been eliminated. Winner of game #28 receives as bye. W21 plays W29, W30 plays L31, W26 plays W31.

Round 6 Losers of games 32 and 33 have been eliminated. Five teams remain (W28, W32, W33, W34 and L34). One team is undefeated. If the undefeated team is 5 - 0, they receive the bye. Otherwise, draw for the bye from the teams that are eligible to receive a bye. Please refer to section P5-1v) for rules applicable to byes. In either case, match four remaining teams avoiding previous match ups where possible. Where avoiding

Round 7 Three or four teams remain. If three remain, one is undefeated. Use Bracket A. If four teams remain, all have one loss, use Bracket B.

Bracket A:

Round 7: Draw for bye if necessary. Remaining two teams play.

Round 8: Two or three teams remain. If three use A2. Draw for bye. If two, use A3.

Round 9: In A2, Game #39 is Championship game. In A3 if necessary.

Bracket B:

Round 7: Four teams remain. All with a loss, match teams, avoiding previous match ups if possible. If not, draw for pairings.

Round 8: W37 plays W38 for Championship.

SCHEDULE TO BE FOLLOWED FOR A 21 TEAM TOURNAMENT

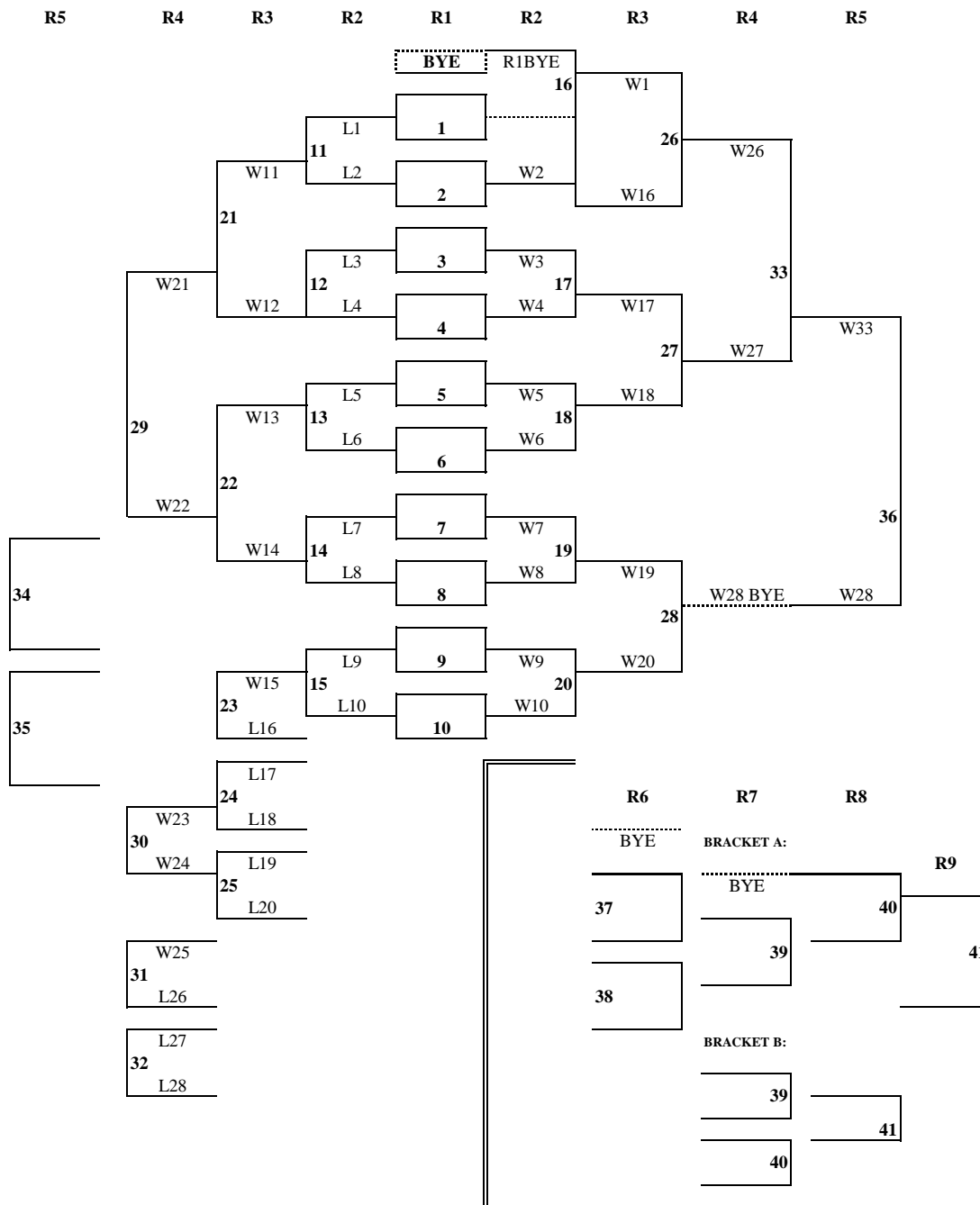

Round 1:

First team drawn receives the bye. Draw for pairings games one through nine.

Round 2:

Winner of game 1 receives a bye.

Round 3:

Losers of games 11, 12, 13, 14 and 15 have been eliminated.

Round 4:

Losers of games 21, 22, 23, 24, 25 have been eliminated. Note: 3 teams remain undefeated. Winner of game 28 receives the bye. Please refer to section P5-1v) for rules applicable to byes.

Round 5:

Losers of games 29, 30, 31, 32 have been eliminated. At this point, 7 teams remain. Winners of games 28 and 33 will play each other. A draw will be made to determine the bye team from the 5 teams with a loss. See section P5-1v). The other 4 teams will be paired, avoiding previous matchups where possible.

Round 6:

Losers of games 34 and 35 have been eliminated. 5 teams remain, 1 is undefeated. If the undefeated team is 5-0, they receive the bye. Otherwise, draw from amongst the teams that have not had a bye to determine the bye team. See section p5-1v) for rules applicable to byes.

Round 7:

3 or 4 teams remain. If 3, use Bracket A and draw for the bye if necessary. If 4 teams remain, all have had a loss. Match teams avoiding previous matchups where possible.

Round 8:

Two teams remain. One may be undefeated.

Round 9:

If necessary.

SCHEDULE TO BE FOLLOWED FOR A 23 TEAM TOURNAMENT

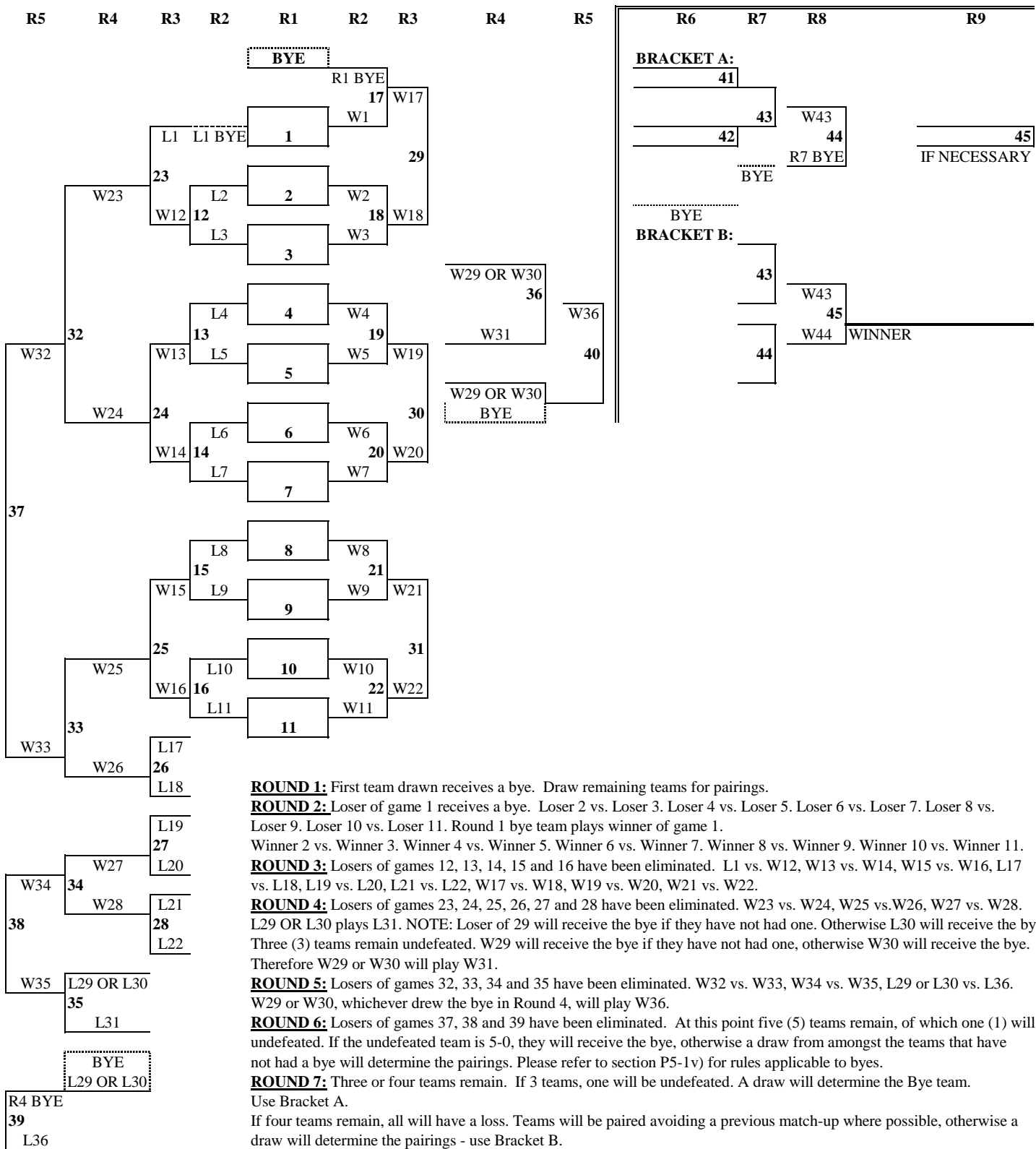

ROUND 1: First team drawn receives a bye. Draw remaining teams for pairings.

ROUND 2: Loser of game 1 receives a bye. Loser 2 vs. Loser 3. Loser 4 vs. Loser 5. Loser 6 vs. Loser 7. Loser 8 vs. Loser 9. Loser 10 vs. Loser 11. Round 1 bye team plays winner of game 1.

Winner 2 vs. Winner 3. Winner 4 vs. Winner 5. Winner 6 vs. Winner 7. Winner 8 vs. Winner 9. Winner 10 vs. Winner 11.

ROUND 3: Losers of games 12, 13, 14, 15 and 16 have been eliminated. L1 vs. W12, W13 vs. W14, W15 vs. W16, L17 vs. L18, L19 vs. L20, L21 vs. L22, W17 vs. W18, W19 vs. W20, W21 vs. W22.

ROUND 4: Losers of games 23, 24, 25, 26, 27 and 28 have been eliminated. W23 vs. W24, W25 vs. W26, W27 vs. W28. L29 OR L30 plays L31. NOTE: Loser of 29 will receive the bye if they have not had one. Otherwise L30 will receive the bye. Three (3) teams remain undefeated. W29 will receive the bye if they have not had one, otherwise W30 will receive the bye. Therefore W29 or W30 will play W31.

ROUND 5: Losers of games 32, 33, 34 and 35 have been eliminated. W32 vs. W33, W34 vs. W35, L29 or L30 vs. L36. W29 or W30, whichever drew the bye in Round 4, will play W36.

ROUND 6: Losers of games 37, 38 and 39 have been eliminated. At this point five (5) teams remain, of which one (1) will be undefeated. If the undefeated team is 5-0, they will receive the bye, otherwise a draw from amongst the teams that have not had a bye will determine the pairings. Please refer to section P5-1v) for rules applicable to byes.

ROUND 7: Three or four teams remain. If 3 teams, one will be undefeated. A draw will determine the Bye team. Use Bracket A.

If four teams remain, all will have a loss. Teams will be paired avoiding a previous match-up where possible, otherwise a draw will determine the pairings - use Bracket B.

ROUND 8: Two teams will remain. If using Bracket A, one team will be undefeated. Should they lose, a round 9 will be necessary to determine the winner. If using Bracket B, both will have a loss and the winner will advance.

OBA ELIMINATION TOURNAMENT PROCEDURES

- a) The OBA Elimination Tournament is sanctioned by the OBA in order to produce an Ontario representative to the National Championship Tournament sponsored by the Canadian Federation of Amateur Baseball.
- b) All OBA Elimination Tournaments and OBA Elimination Tournament games shall be governed by the Constitution of the OBA, the Official Rules of Baseball, the OBA Tournament Rules and these OBA Elimination Tournament Rules.
- c) The OBA, the local Host Association and their respective officials accept no responsibility for any injuries to any player, team official, or any other person, either on or off the field during an OBA Elimination Tournament.
- d) Only OBA registered teams and players may participate in an OBA Elimination Tournament.
- e) Teams participating in an OBA Elimination Tournament shall automatically be classified by the OBA as follows:

PeeWee	AAA
Bantam	AAA
Midget	AAA
Junior	A
Senior	A

- f) Applications to enter an OBA Elimination Tournament must be at the OBA Office by June first. The entry fee (payable to OBA), written permission from the team's Affiliated Association and a photocopy of each coach's and/or manager's NCCP Level I certification plus Level II technical accreditation and NCCP passport number must accompany the application. Applications to enter an OBA Elimination Tournament received after June first, and prior to the draw being held for such tournament, shall be accepted if accompanied by a late fee of \$100.00 for each day after June first that the application is late.
- g) An information package, including a complete schedule of OBA Elimination Tournament games, rules and an OBA approved tournament chart, will be forwarded to each local host by the OBA Series Chair by June 15th.
- h) Where a team drops out of an OBA Elimination Tournament 7 or more days prior to the start of the tournament, the schedule for the tournament, if published, will be redone. If a team drops out of an OBA Elimination Tournament less than 7 days prior to the tournament and the schedule for the tournament has been published, any scheduled games not played due to teams having dropped out of the tournament shall be considered defaults and shall count as a game played and not as a bye in the tournament and the published chart shall not be changed. A team which drops out of an OBA Elimination Tournament after the draw shall forfeit its entry fee and shall not be classified for the OBA Play-offs.

Note: If possible a late entry team may be used as a substitute where applicable.

- i) The OBA Elimination Tournament shall be a double loss knock-out tournament and may require play-downs to be played from July 17-19, 2009 with the championship tournament being played from July 31-August 3, 2009. Notwithstanding the foregoing, at Junior only, the Elimination Tournament will run as a regional tournament July 17-19 and the elimination tournament July 24-26, 2009. The published chart for OBA Elimination Tournaments may provide for predetermined byes in early rounds (not exceeding the fourth round) of the OBA Elimination Tournament. Thereafter, byes are to be awarded as follows:
 - i. No team shall receive a back-to-back bye in successive rounds.
 - ii. No team shall receive a second bye until all remaining teams have received their first bye.
 - iii. If more than 1 team is eligible for a bye the undefeated team shall automatically receive the bye.
 - iv. If more than 1 team is eligible for a bye, the bye team will be determined by means of a draw with the first team drawn receiving the bye, and the remaining teams drawn to fill each game slot from top to bottom as drawn.
- j) A local host shall not use any special or local rules in any OBA Elimination Tournament or game(s).
- k) Teams must be prepared to play on the Friday, if necessary. In all series up to and including Bantam, no game shall start after 9:30 p.m. on any day and no new inning may begin after 12:59 a.m. (or such earlier time as may be provided by local by-law).
- l) 18 players are eligible to be included on OBA Elimination Tournament rosters for Peewee, Bantam and Midget. For Junior and Senior rosters at OBA Elimination Tournaments 25 players will be allowed. (For Baseball Canada Championships, rosters for Peewee, Bantam, Midget, and Junior are limited to 18 players. The Senior roster for Baseball Canada Championships may include 21 players).
- m) Coaches must have a copy of their OBA approved roster with them in case it is required during the tournament. The coach must write their OBA roster number in the space provided on the sign-in sheet. Failure to do so will result in the team being assessed a fine of \$200.
- n) The tournament host will maintain a sign-in list for all umpires used in the tournament and forward the sign-in list to the Tournament Chair with the Tournament Report.
- o) Teams must be given a minimum of 30 minutes from the time of completion of the last game that they played, until the start of their next game. If a team must travel from another location, appropriate travel time shall be added to the 30 minute period.
- p) Barring extenuating circumstances, if 1 team is not able to start a game, within 30 minutes of the scheduled starting time for such game, the game will be forfeited to the other team and the offending team will not be allowed to continue in the tournament. The game will count as a game played and not count as a bye in the tournament and the published chart shall not be changed.
- q) The home team will be decided by a coin toss prior to each OBA Elimination Tournament game with the team from the municipality furthest away from the tournament site calling the toss.
- r) Awards shall be presented to the champions and finalists.

- s) The OBA Convenor's Report and specified attachments must be mailed (postmarked) to the OBA Tournament chair within 10 days following the tournament.

P7 EXHIBITION GAMES AND TOURNAMENTS

Section P7.1 PLAYING NON-REGISTERED TEAMS AND PLAYERS

- a) Any registered team or player shall automatically suspend themselves upon playing with or against any team or players which are not registered with the OBA without first securing written permission from the OBA Board of Directors or the OBA Office; except where an entire team is playing an exhibition game(s) with teams up to and including Midget age, permission may be granted by the secretary of the Affiliated Association to which the team belongs.
- b) Any OBA team participating in a non-OBA sanctioned tournament without permission of the OBA shall be liable for a fine of up to \$500 and may be suspended from further participation in any OBA sanctioned tournament and the OBA play-offs.

Section P7.2 EXHIBITION GAMES AND OUT OF PROVINCE PLAY

- c) All teams registered with the OBA, which desire to participate in exhibition games, must first secure the permission of their Local Association and Affiliated Association. (Any game or tournament that has not been sanctioned by the OBA is defined as an exhibition game. Local Associations and Affiliated Associations may approve exhibition games where their own member teams are playing against each other within their own boundaries.)
- d) Teams wishing to play an exhibition game(s) outside the Province of Ontario must first secure the permission of their Local Association and Affiliated Association and submit same to the OBA Office for approval.
- e) Teams wishing to play an exhibition game(s) involving a team(s) from outside the Province of Ontario must first secure the permission of their Local Association and Affiliated Association and submit same to the OBA Office for approval.
- f) In an exhibition game(s) teams may only use players who have signed OBA approved rosters. Except with the permission of the management of the team with which the player is rostered, a team may not use pick-ups in an exhibition game.
- g) Applications can be made to the OBA Board of Directors to make exceptions to the rule.

Section P7.3 OPEN, INVITATIONAL AND INTERNATIONAL TOURNAMENT PROCEDURES

- a) Any team, Direct Entry, Local Association or Affiliated Association, wishing to hold a tournament where 3 or more teams are competing, must first apply for permission to hold same from the OBA Board of Directors. A fee of \$50.00 must accompany each application only if teams are from outside the area Affiliated Association. This application must have been approved by the Affiliated Association secretary in the area from which it came. If more than 1 series (e.g. Minor and Major) is held, a \$50.00 fee must be paid for each series.
- b) Upon receipt of each of the items in a) above, the OBA Tournament Chair will consider the tournament request and, if approved, the OBA office will forward a tournament package to the tournament host.
- c) The OBA Tournament Chair shall have the power to appoint an OBA Representative to any OBA sanctioned tournament.
- d) A list of all OBA sanctioned tournaments will appear on our website, www.baseballontario.com.
- e) A declared representative from an Affiliated Association must first honour its OBA Play-off and Affiliated Association obligations before participating in a tournament.
Any team not fulfilling its commitment to any OBA sanctioned tournament may be fined and/or suspended from further participation in any OBA sanctioned tournament and the OBA Play-offs provided that this information is provided to the OBA Tournament Chair in writing. The fine for a team not fulfilling its commitment to a tournament is \$500. Any fine collected (after any appeals) is to be split 50/50 between the OBA and the tournament host.
- f) Non-OBA teams registered in Ontario may compete in open, invitational or international tournaments, only if permission of the OBA Tournament Chair is requested. Such non-OBA teams must provide proof of accident and liability insurance to the tournament host prior to being permitted to play in the tournament.
- g) The Host Committee must notify each application of acceptance or rejection into the tournament within 10 days following the final deadline date. Failure to comply with such provisions may lead to the tournament not being approved the following year.
- h) A final date for applications for acceptance to the OBA sanctioned tournament must be in the hands of the Host Association at least 21 days in advance of the first date of the tournament.
- i) Before distribution to the teams by the Tournament Host Association the complete schedule must be forwarded to the OBA Tournament Chair at least two weeks prior to the tournament for approval. Failure to comply with such provisions may lead to the tournament not being approved the following year.
- j) The Complete schedule of tournament games must be sent to each participating team at least one week prior to the first game.
- k) Any special or local rules must be sent to the OBA Office and approved by the OBA Tournament Chair prior to distributing same. A copy of these rules must be sent to each team along with the tournament schedule. No local rules shall contravene any OBA playing rule or tournament rule.

- l) Where a tournament is cancelled prior to any game being played the total tournament entry fee must be refunded to all teams. Where a tournament is cancelled after games have been played the teams will be refunded on a pro rata basis for the games not played.
- m) No special concessions will be granted to any team(s) participating in any of these tournaments.
- n) The tournament host is responsible for ensuring that each umpire is properly carded. Teams may request that the umpires produce their umpiring card prior to the game to prove certification. Teams may not protest a game based on the carding of the umpires during or after a game.
- o) Prior to participating in any game of a sanctioned tournament all players and coaches must sign the approved OBA tournament sign-in form. These forms, following the tournament, shall be forwarded to the OBA Tournament Chair.
- p) Coaches must have a copy of their OBA approved roster with them in case it is required during the tournament. The coach must write their OBA roster number in the space provided on the sign-in sheet. Failure to do so will result in the team being assessed a fine of \$200. Teams entering tournaments without a roster approved by their affiliate association registrar may be permitted to play at the discretion of the tournament host so as not to disrupt the tournament. The host must advise the OBA Tournament Chair immediately following the tournament of any teams not having team roster numbers. Failure to comply with such provisions will lead to the tournament being fined \$200 and may not be approved the following year.
- q) No tournament game shall start before 8:00am on a Saturday, Sunday or holiday, and no tournament game shall start later than 9:30pm on any night.
- r) Teams must be given a minimum of 30 minutes from the time of completion of the last game that they played, until the start of their next game, without jeopardy of forfeit. If a team must travel from another location, appropriate travel time shall be added to the 30 minute period.
- s) No team may play more than 3 games in a calendar day without its written consent. A suspended game shall count as a game played on both the day it commenced and the day it is completed if 3 or more innings have been played each day. If less than 3 innings are played on the day it is completed, it will not count as a game played on that day.
- t) In tournaments where tie breaking rules are required, the following tie breaking rules will be used for each placement independently:
 - i. Winner of the head to head game will advance
 - ii. Team with smallest runs against ration (runs allowed / number of defensive innings played)
 - iii. Team with the highest runs for ration (runs scored / number of offensive innings played)
 - iv. Coin toss.
- u) The OBA Convenors Report and specified attachments must be mailed (postmarked) to the OBA Tournament Chair within 10 days following the tournament.
- v) If these rules are not adhered to, the tournament shall not be approved or, if already approved, the host association may be fined \$200.00 and the tournament may not be approved the following year.
- w) The OBA Tournament Chair shall provide, immediately, to the Affiliated Associations a listing of any and all disciplinary problems with managers, coaches, players or other team personnel, as reported by the tournament convenors.
- x) Tournament hosts may determine what awards they give to teams and/or players entering their tournaments, provided, however, that cash prizes may only be given to teams (not players) at Junior or Senior tournaments.

Q1 APPROVED PLAYING RULES OF T-BALL

Section Q1.1 GENERAL

- a) The Game:

T-Ball is a game of baseball between 2 teams of 11 players, under the direction of a manager and coaches played in agreement with the Official Playing Rules (Q2-1 d) under the authority of an umpire or umpires on a recommended T-Ball field. It is designed to get young people interested in the game of baseball by stressing and maintaining active participation of all the players; with mandatory alternation of players at a game (Q2-4 c), with the offensive team utilizing the 11 players as batters to score as many runs as possible and the defensive team using 2 extra outfielders to make as many outs as possible in accordance with the rules.
- b) Insurance:

Liability insurance must be carried by all T-Ball leagues. Proof of Liability insurance must be sent to the OBA Office.
- c) Official Playing Rules:

T-Ball is a game of baseball played in accordance with regular baseball rules with the incorporation of the rules contained in this booklet and OBA Playing Rules and Regulations.
- d) Rosters:

See OBA Rules. Min. - 11. Max. - 25.
- e) Field Decorum:
 - i) The actions of players, managers, coaches, umpires and league officials must be above reproach.
 - ii) The use of tobacco, alcohol or illicit drugs in any form is prohibited on the playing field, benches or in dugouts.
 - iii) Players or coaches while participating in a scheduled game are not permitted to deliberately harass or direct discourteous remarks at the officials or any member of the opposing team.

- iv) Managers, coaches or players engaged or persisting in conduct contrary to the spirit, principles and objectives of good sportsmanship in T-Ball, shall receive a single warning from the umpire. If the offences continue, offender or offenders will be removed from the game.
- v) Anyone removed from the game must leave the playing field and the spectator area. Failure to do so could result in a forfeiture of the game (Q2-4 b).
- vi)

Section Q1.2 EQUIPMENT

- a) Uniforms:
Uniforms shall consist of a sweater, cap, pants and socks and must be worn by all players and coaches while participating in a game. Sweaters shall be individually numbered.
- b) Gloves:
 - i) The catcher may wear any type of baseball glove.
 - ii) The first baseman shall be permitted to wear a trapper or fielder's glove.
 - iii) All other members of the fielding team must wear fielder's gloves.
- c) Helmets:
Each team must supply at least 6 double ear-flapped protective helmets with chinstraps. They must be worn when the players are at bat, while running the bases, while acting as batboy and while in the next batter's circle. Chinstraps must be worn as designed by the manufacturer.
- d) Footwear:
Shoes with metal cleats are prohibited. Shoes with moulded rubber cleats may be used.
- e) Catcher's Equipment:
The catcher's equipment shall consist of a chest protector, shin guards, facemask and helmet, which must be worn during practices, game warm-ups and regular games. A metal, fibre or plastic cup-type athletic support must also be worn.
- f) It is recommended that all players wear athletic supports of the plastic cup-type.
- g) The Ball:
The ball shall weigh not less than 5 oz. or more than 5.25 oz. It shall measure not less than 9 in. or more than 9.25 in. in circumference. OBA Approved Balls.
- h) The Bat:
The bat shall be round and made of wood or aluminium. It shall not be more than 33 in. in length. It shall not be more than 21/4 in. in diameter at its largest part and not less than 1 1/16 in. in diameter at its smallest.
- i) The Batting Tee:
The batting tee shall be a stand that will be placed on home plate for the purpose of holding the ball for the players to swing at. It should be portable and adjustable to the height of the player's choice. Each team may use its own tee when at bat. Safety must be a key element when selecting a batting tee.
- j) The Playing Field:
 - i) The distance between all bases shall be 60 ft.
 - ii) The distance between the point of home plate and the pitcher's rubber shall be 50 feet.
 - iii) Batter's boxes shall be 3 ft. wide and 6 ft. long. The inside line shall be parallel to and 4 in. away from the side of home plate. It shall extend 3 ft. in front of and 3 ft. behind the centre of home plate.
 - iv) The coach's box shall be 4 ft. wide and 8 ft. long, and shall not be closer than 6 ft. to the base lines.
- k) The infield arc is a line dividing the infield playing area from the outfield. It has a 50 ft. radius from the centre of the playing line (Q2-3 a) extending from foul line to foul line.

Section Q1.3 DEFINITIONS

- a) A "playing line" is an imaginary line running directly from first base to third base, which is a guide for the plate umpire to determine a fair hit ball.
- b) A "forfeited game" is a game declared ended by the umpire for violation of the rules. The score will be recorded 5-0 for the offended team.
- c) A "fair hit ball" is a legally batted ball that in the plate umpire's opinion will or could have firmly crossed the playing line (Q2-3 a) in fair territory, even if it is fielded before crossing the line.
- d) A "dead hit ball" is a legally batted ball that, in the umpire's opinion will not or could not have firmly crossed the playing line, even if fielded in front of the playing line. This excluded a ball put into play by an illegal swing (Q2-3 l). If the ball is caught in flight by the defensive team, the batter is out and the ball is in play until time is called.
- e) A "strike" is when:
 - i) the ball is swung at by the batter and is completely missed.
 - ii) the ball is a dead hit, fouled or put into play by an illegal swing (Q2-3 l) by the batter when he/she has less than 2 strikes.
- f) An "illegally batted ball" is when the batter hits the ball, either dead, fair or foul with one or both feet on the ground entirely outside the lines of the batter's box (Q2-3 k).

- g) A “fielder’s choice” is when any defensive player has control of the ball in the infield area (Q2-3 h) and in the judgment of the plate umpire there is no attempt to make a play on any of the base runners, time will be called, and the base runners, in the judgement of the umpires, will be held on the base they last occupied or the unoccupied base they were approaching when time was called. A player raising his/her hand with the ball therein above his/her head will not automatically attain a call of time by the umpire.
- h) The “infield area” is the area, in the judgement of the plate umpire, in which the defensive infielders would normally play in performance of their duties. It also includes the adjacent foul territories which are encompassed by the playing line being extended to the playing field boundaries.
- i) An “appeal” must be made before “play” is called for the next batter; in the case of the last batter, it must be made before the last defensive player is off the field.
- j) A “lead-off” is when a runner is off his/her base when the batter hits the ball off the tee.
- k) The “batter’s box” is an area on each side of home plate, within which the batter shall have both his/her feet during his/her time at bat.
- l) An “illegal swing” is when the batter does not take a full swing or chop swings downward at the ball. This is considered bunting and is contrary to Q2-4 a). (Penalty see Q2-5 n).

Section Q1.4 GENERAL RULES

- a) In T-Ball there shall be no pitching to the batter, therefore there will be no base-on-balls awarded; there is no bunting and the infield fly rule does not apply.
- b) Each team shall have a starting line-up of 11 players. If at any point during the game a team cannot field the 11 players, the game will be forfeited to the opposing team.
- c) All players listed in the game line-up in which their team is participating must be scheduled to play at least 2 innings of a 5 inning game. It is compulsory that players play a complete inning when alternated and must be put in at the beginning of an inning.
- d) 10 minutes before the scheduled starting time, the manager must give a copy of his/her batting line-up for each of the 5 innings to be played to the opposing manager and the official scorekeeper. A player must be listed to bat in the same batting position for each inning until substituted. He/she may return to the same or any other batting position in the line-up following the inning in which he/she was substituted. No changes to the line-up will be permitted in the first 3 innings of the game, except in the case of injury or sickness. (A player substituted for because of injury or sickness may not re-enter the game until the following inning.) Prior to the start of the fourth and/or subsequent innings, valid additions or changes to the line-up must be made before the plate umpire calls play for the first batter at the beginning of that inning. All line-up changes must be reported to the plate umpire, official scorekeeper and the opposing manager. If a player is listed on the game score sheet but is not in attendance at the game when his/her scheduled time at bat or his/her turn to take a defensive position occurs, the offending team shall forfeit the game. Late arriving team players who are not listed on the home score sheet may only be inserted into the line-up to play the fourth and fifth innings at the manager’s discretion (Q2-4 c).
- e) The “batting orders” must be followed for each inning. A batter who fails to bat in his/her proper batting position shall be declared out on an appeal by the defensive team, if another player completes a time at bat in his/her place. However, the proper batter may take his/her place in the batter’s box at any time before the improper batter becomes a runner or is put out and any strikes will be assumed by the proper batter. If the improper batter becomes a base runner or is put out and the proper appeal is made the plate umpire shall:
 - i) declare the proper batter out,
 - ii) nullify any advances or scores made by the base runners because of a ball batted by the improper batter, and
 - iii) the next batter will be the player in the batting position following the player who was called out because of missing his/her turn at bat.

If the appeal is made too late then the improper batter becomes legal and the player in that batting position is considered to have completed his/her turn at bat. The next batter will be the player in the next batter position in the line-up.
- f) If at the time a game is scheduled to begin, a team does not have a minimum of 11 eligible players, a maximum extension of 15 minutes will be allowed before the plate umpire declares the game forfeited to the non-offending team.
- g) If 15 minutes past the scheduled game time, neither team can field 11 eligible players the umpire shall declare a double forfeit.
- h) Each “defensive team” shall have:
 - i) a catcher who shall play a position normally taken by the catcher behind home plate, far enough back so he/she does not interfere with the batter while batting,
 - ii) a pitcher who shall play in the infield and must assume a set position with both feet on the pitcher’s rubber until the ball is hit,
 - iii) a first baseman, a second baseman, a third baseman and a shortstop who shall play in positions regularly played by these infielders and they shall not cross the playing line until the ball is hit. Penalty - in the event a defensive player, in the judgement of the umpire, does cross the playing line before the ball is hit the umpires will call time immediately and the ball is dead,
 - iv) 5 outfielders who shall play in the area regularly played by outfielders, and
 - v) a maximum of 4 adults in the dugout.
- i) The “offensive team” shall have no more than 2 adults in the dugout and will be allowed only 2 coaches in the coaching boxes (1 near first base and 1 near third base) for a total of 4. Coaches and managers shall:
 - i) be adults,
 - ii) remain within the dugout or within the coaches boxes at all times,
 - iii) not physically assist any runner while he/she is in play (in the event he/she does, the base umpire will call the runner out at the time of the infraction), and
 - iv) talk to members of his/her own team only.

j) A “regulation game” will consist of 5 complete innings, provided 1 team has scored more runs than the other. If the score is tied at the end of 5 innings, play is continued until 1 team has scored more runs than the other in an equal number of innings or when the home team has scored the winning run in the last inning. In the event the umpire terminates the game before the end of the fifth inning and there has been at least 3 completed innings played, the score will revert back to the last completed inning. In the event that a league game is tied after 3 or more completed innings and halted by the umpire, it shall be scored a tie. In the event that a league game is halted before 3 complete innings, it shall not be considered a regulation game and will be replayed from the beginning at a later date. In tournament play, if a game is halted before it is a regulation game but at least 1 inning has been completed, the game will continue from the exact point play was halted.

k) **Protesting a Game:**

The managers of the contesting teams only shall have the right to make protests. A protest will not be considered on a decision involving umpire’s judgement but only when based on the violation or interpretation of a playing rule, an eligible player or if a player does not play at least 2 innings of a 5 inning game. Protests shall be made as follows:

- i) The protesting manager shall immediately and before any further play begins, notify the plate umpire that he/she is playing the game under protest.
- ii) Following such notice the umpires shall consult with each other and if they are convinced that the decision is in conflict with the rule the decision shall be reversed. If, however, after consultation they are convinced that the decision is not in conflict with the rules, the plate umpire shall announce that the game is being played under protest and play will continue.
- iii) Protests made due to the use of an ineligible player or a player not playing enough innings may be considered only if made to the plate umpire before the last batter of the final inning or half inning has completed his/her turn at bat.
- iv) Any protest for any reason whatsoever must be submitted in writing within 48 hours after completion of the game by the protesting manager and the plate umpire to the proper league officials who shall deal with it as they see fit. See OBA Rules and Regulations.

In tournament play, all protests are settled on the playing field before any further play continues. The umpires shall consult with each other and if they cannot resolve the protest between them, they shall call in the tournament umpire-in-chief or protest committee and this decision is non-appealable.

Section Q1.5 PLAYING RULES

a) To begin the game, the plate umpire shall instruct the home team to take their positions in the field, place the tee of the batting team on home plate and call “play” for the first batter of the offensive team.

b) The batter becomes a base runner when:

- i) he/she hits the ball hard enough to cross the playing line in fair territory (Q2-3 a and c).
- ii) the catcher interferes with him/her while he/she is attempting to hit the ball. The batter is awarded first base, the ball is dead and no runner may advance except those forced by the batter becoming a base runner. In the event that the batter, in spite of the interference, hits the ball fairly (Q2-3 c) and reaches any base safely and all runners have advanced at least 1 base safely, then the interference is disregarded. In the case of catcher interference on the last batter while he/she is attempting to hit the ball, the ball is dead, no runners may advance and the last batter is allowed to continue his/her turn at bat with the same count. In the event the last batter, in spite of the catcher interference, hits the ball fairly and reaches home plate safely, the ball is alive and the catcher interference is disregarded. However, in all cases of catcher interference, the offensive manager has the option of accepting or refusing the catcher interference.

c) A batter is out when:

- i) his/her fair hit, dead hit, foul fly or fly ball put into play by an illegal swing is caught by a member of the defensive team. The ball is alive and in play until time is called.
- ii) he/she hits the ball illegally. The ball is dead and runners may not advance (Q2-3 f).
- iii) he/she has 3 strikes called on him/her. The ball is dead and runners may not advance (Q2-3 e).

d) A base runner is out:

- i) on a force play.
- ii) when he/she is tagged.
- iii) when running off his/her baseline to avoid a tag.
- iv) when he/she is hit by a fair batted ball, either on or off his/her base, before the ball has touched or passed an infielder trying to make a play on the ball not including the pitcher. The ball is dead and no runner may advance.

e) **Lead-offs:**

No player on the offensive team, while a base runner, shall take a lead-off from the base he/she is on until the batter has hit the ball from the tee. When any runner has taken a lead-off, the base umpire shall indicate same by dropping a red flag. Play is permitted to continue and all runners are in jeopardy. At the end of the play when time is called, any outs will stand and all other runners will return to their original bases and the batter, if not put out will return to bat with the same count. In the event that lead-off occurs on the last batter, play will continue and all legal runs are allowed to score except player(s) who lead-off.

f) If a fielder intentionally drops a fly ball or line drive, when first base is occupied, the force is removed and the base runner must be tagged.

g) **Overthrows:**

Base runners may advance when a ball is overthrown to any base until such time a defensive player has control of the ball in the infield area and there is no attempt to make a play (Q2-3 g and h). In the event the overthrown ball leaves the playing field, the base runners

shall be permitted to advance to the base they were approaching when the ball was thrown plus 1 more base. Runners with last batter status (Q2-5 i) are allowed to continue to score.

- h) The offensive team's turn at bat ends when:
 - i) the last batter has 3 strikes.
 - ii) the last batter has hit the ball illegally (Q2-3 f).
 - iii) when the catcher (only) touches home plate with the last batter's fair hit ball (Q2-3 c) in his/her possession. The ball must be thrown over the playing line (Q2-3 a) at least once on its way to the catcher unless the fair hit ball was fielded in front of the playing line. The pitcher, only, is allowed to assist the catcher in the home plate area. Penalty - In the event a defensive player other than the pitcher, in the judgement of the umpire crosses into the home plate area, the umpire will call time and allow all legal runs to score.
 - iv) base runner with last batter status (Q2-5 i) is hit by a fair hit ball either on or off his/her base before the ball is touched by an infielder or has passed an infielder, excluding the pitcher, the ball is dead and no runs may score.
 - v) the last batter's fly ball is legally caught and there are no runners on the bases.
- i) Last Batter Status:

Any players on the offensive team who are base runners when the last batter is at bat are regarded in the same manner as the last batter and no defensive play can be made on them on the bases. They are all forced to home plate when the last batter has hit the ball fairly (Q2-3 c).
- j) In the event the last batter's fair hit ball leaves the playing field by going over the outfield fence, either in flight or bouncing over, it will be considered a home run and all runners having last batter status will be allowed to score. However, if the ball goes under or gets caught in the outfield fence and in so doing interferes with the fielder's chances to field the ball, all base runners will be allowed to score but not the batter.
- k) In the event that the last batter of the offensive team is out on a fly ball, the players who are base runners shall be permitted to score, provided they are on the base when the ball is caught or they retouch it after the ball is caught before touching the next base. These runners have to score prior to the ball being returned to home plate.
- l) In the event that the last batter of the offensive team or any base runner with last batter status is obstructed in any manner by any defensive player while running the bases, it shall be the discretion of the umpire as to how far he/she would have advanced had there been no obstruction.
- m) A run does not count when a runner with last batter status:
 - i) reaches home plate after the plate has been legally touched by the catcher.
 - ii) has led-off and reaches home plate safely.
 - iii) has not tagged up and reaches home plate safely.
- n) Illegal Swing:

When a batter puts a ball into play by an illegal swing (Q2-3 l) the plate umpire shall indicate same by dropping a red flag; play is permitted to continue and all runners are in jeopardy. At the end of play, when time is called, all outs will stand and all other base runners will return to their original bases. The batter, if not put out, will resume his/her turn at bat with a strike added to his/her count (no third strike can be applied, Q2-3 e ii). In the event the last batter puts the ball in play by an illegal swing it shall be considered a dead ball unless caught in flight by a defensive player.

Section Q1.6 UMPIRES

- a) Once the batting line-ups have been exchanged the plate umpire takes charge of the game and takes his/her place behind home plate.
- b) The decisions of the umpire shall be final; however, the managers of each team shall be entitled to ask for permission to approach the umpires for an interpretation of the rules. No umpire shall overrule any other unless invited into consultation.
- c) The umpires are the only ones that can call "time".
- d) To resume play after time has been called, the plate umpire will call for the next batter, and after the next batter has stepped into the batter's box, the umpire will place the ball on the tee and call "play". The batter is then allowed to hit.
- e) In the interest of safety, the plate umpire must remove the tee from home plate to prevent any interference with a play at home plate. Failure to do so will be no cause for the umpire to change the results of the play.
- f) The plate umpire must call out all strikes, dead hits and foul balls as quickly as possible. He/she must also indicate an illegal swing by dropping a red flag.
- g) The plate umpire shall notify opposing managers of any changes or additions to the original line-up as reported to him/her (Q2-4 d).
- h) Base umpires shall:
 - i) judge the position of the runners when the ball is thrown out of the playing area (Q2-5 f),
 - ii) watch for and indicate lead-offs (Q2-5 d) and inform the plate umpire which runner(s) lead-off if they have last batter status (Q2-5 j),
 - iii) watch for and inform the plate umpire of runners that do not retouch when the last batter's fly ball is caught (Q2-5j) and
 - iv) hold up runners when time is called (Q2-3 g).
- i) All umpires must make sure the fielders are all behind the playing line and the pitcher is in his/her proper position before play is called for the next batter.
- j) It is the duty of the plate umpire, after he/she has been notified, to call out "last batter". Failure to do so does not nullify the play.
- k) The plate umpire may terminate a game before its completion for reasons of darkness, bad weather or dangerous field conditions, etc.
- l) The umpires shall have the authority to rule on any situation not covered specifically in the Official Playing Rules.

Q2

THE APPROVED PLAYING RULES OF ROOKIE BALL

Section Q2.1 REGULATIONS

All OBA Rules & Regulations pertaining to membership, territorial rights, registration, players signing, fees, insurance, classification, OBA Play-offs, and tournaments shall apply as stated in the current version of the Constitution of the OBA as amended each year at its Annual Meeting.

The Approved Playing Rules of Rookie Ball apply to both Junior and Senior Rookie Ball.

Section Q2.2 DIAMOND LAYOUT

- a) The pitching machine is placed directly in front of home plate at a distance of 44 ft.
- b) An 8 ft. diameter safety circle shall be marked off directly in front of home plate and its centre shall be 44 ft. from home plate. No player is permitted to enter the safety circle, which is considered a dead ball area. Enter means that any part of the body enters the safety circle.
- c) Electrical cord must run along or under the ground from the pitching machine to the electrical source.

Section Q2.3 PLAYING RULES

- a) A team shall comprise of a minimum of 10 players and a maximum of 25 players, all signed to team rosters of the series and classification of the team entered. Each team must have at least 1 manager and/or 1 or more coaches signed to a team roster clearly marked manager or coach and who shall be responsible for that team.
- b) Each team shall have a catcher, a first baseman, a second baseman, a third baseman, a shortstop, a left fielder, a right fielder, 1 pitcher and 2 centre fielders in the line-up. A team may play as long as it has 9 players at the game. If it drops to 8 or few players at a game, then the game is forfeited to the other team.
- c) The pitcher must stand beside the pitching machine outside of the safety circle and behind the release point of the pitching machine. Lines shall be drawn from the release point to 4 ft. beyond the circle. The pitcher must have both feet on the white line until the ball is released from the machine. The machine shall be 44 ft. from home plate. Only the pitcher may return a live ball to the operating coach with runners on base. The pitcher must wear a regulation batting helmet with an attached chinstrap. The pitcher must not in any way break the plane of the 8 foot diameter circle around the machine whether stepping on the circle line or reaching in. Play will be called dead and 1 base will be awarded. All other forced runners will move 1 base. This only applies if the pitcher makes contact with the ball. Infielders can ask for time in the infield area. Time will be given at the umpire's discretion. **Note:** The ball does not have to go back to the pitcher before an infielder may ask for time.
- d) The pitching machine speeds cannot be altered except at the end of an inning. Any tampering with the machine speed by the coach feeding the machine shall result in the coach's immediate ejection. If the machine speed is erratic, it shall be corrected by the umpire. (This may be done at any time.) Machine speed is a maximum of 40 mph and a minimum of 35 mph. Height can be adjusted at any time.
- e) All Rookie Ball baseball games shall be 7 innings or until a winner is declared. 5 innings shall constitute an official game.
- f) Each batter shall receive a maximum of 5 strikes as called by the umpire. The batter shall not be called out if the 5th strike is called a foul ball. If a ball crosses the plate over the batter's head or bounces into the dirt, the umpire will not count it as a strike unless the batter swings at the pitch.
- g) Batters cannot walk or bunt. (Bunts are automatic outs.)
- h) There shall be no passed balls or wild pitches.
- i) Base Runners cannot leave the base until the batter makes contact with the ball. If an infraction occurs, the ball will be declared dead and runners may not advance. One (1) warning will be issued and for any further infractions Thereafter the runner will be called out. (Each team may receive 1 warning). No stealing allowed.
- j) If a batted ball hits the pitching machine or any adult in the playing field, then the ball is declared dead and the batter is awarded first base with the corresponding move of any base runners who may be forced to move. The coach feeding the machine must not interfere with any play being made by the defensive team. Otherwise, the batter will be called out and the runners will be returned to their base of origin. In case of the third out the side is retired. If the 10th batter hits the pitching machine, then the ball will be declared dead, the batter will be awarded first base with the corresponding move of any base runners who may be forced to move, and the inning will be over.
- k) The plate umpire shall be behind the catcher. The second umpire is the traditional base umpire.
- l) The on deck batter, the batter and base runners must wear a prescribed protective helmet with flaps covering both ears. Chinstraps are mandatory and will be worn as designed by the manufacturer. Helmets may not be changed except after the inning has been completed, or the player has been retired or has crossed home plate.
- m) Shoes with metal cleats are prohibited.
- n) All catchers are required to wear a mask with throat protector, helmet, chest protector, shin guards, cup and cup type supporter during the game and during any warm-up, machine set-up, etc.

- o) In addition to wooden bats, metal bats shall be allowed in OBA play. These bats shall meet the dimensional requirements specified in Rule 1:10 of the Official Rules of Baseball. The maximum diameter of the bat barrel is 2 3/4”.
- p) All players in uniform (OBA rostered) must be put in a continuous batting order, with the bat person being the exception.
- q) A coach/manager may only communicate positive instructions to his/her players on the field.
- r) Up to 3 games may be played in 1 day.
- s) An inning shall be 3 outs or the maximum of 10 batters. If there are 2 outs when the 10th batter is up, the 3rd out can be obtained by a strike out, a caught fly ball, a force out (when the runner must advance to a base) or a tag play. With 1 out when the 10th batter is up, it is possible to end the inning with a double play (forces, tags, caught fly ball and appeal, etc.). Otherwise, with the 10th batter up, the ball must go to the catcher or the pitcher who must touch the plate to end the inning. (**Note:** only the catcher or pitcher may touch the plate to end the inning.) While not ending the inning unless 3 outs are recorded or all runners (including the batter) are put out, with the 10th batter up, the defensive team can make plays to get the batter or runners out. With less than 2 outs, if the 10th batter is put out on a caught fly ball, all base runners are permitted to tag up and try to advance to home. With the 10th batter up, if the ball proceeds out of play, then the runners advance as prescribed by the Official Rules of Baseball and anyone entitled to advance to home will score.
- t) The infield fly rule does not apply.
- u) The coach operating the pitching machine is required to wear a baseball helmet.
- v) Batters at Rookie Ball must drop the bat and not throw it (intentionally or unintentionally) upon hitting the ball. Penalty, each team shall be entitled to one warning per game. After the warning, any further offences by a team shall result in the batter being declared out, the ball being dead and runners returning to their bases.

Section Q2.4 APPROVED BALLS FOR ROOKIE BALL

Any baseball approved for Mosquito play.

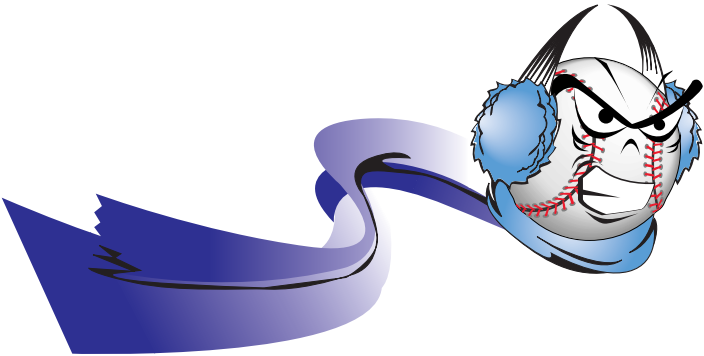

WinterBall

WinterBall is a program designed to attract new participants to the sport of baseball. The program is targeted primarily at elementary schools throughout Ontario with possible application to community centres, local recreation departments, along with boys and girls clubs across the province.

WinterBall is designed for students in Grades 3 – 6 (ages 8-12) as an introductory program that will progress through activities. It contains nine different lesson plans. To ensure students are being taught skills at an appropriate skill and ability level, there are a set of lessons for grades 3 and 4 and another set for students in grades 5 and 6.

If you would like more information on how to get WinterBall into your community's elementary schools, visit www.baseballontario.com or call Baseball Ontario at 519-740-3900!

APPENDIX “A”

GUIDELINES FOR AFFILIATED ASSOCIATIONS

- 1) Affiliated Associations shall agree by and comply with the Constitution, By-Laws and Rules of the OBA according to Article 1.03 a) of the Constitution of the OBA.
- 2) Send a copy of the Constitution of the Affiliated Association to the OBA Office.
- 3) Send a list of the Officers, along with their names, addresses and telephone numbers, of the Affiliated Association to the OBA Office within 30 days of the Annual Meeting of the Affiliated Association.
- 4) Send a copy of the Affiliated Association’s Annual Financial Statement to the OBA Office within 30 days of the Annual Meeting of the Affiliated Association.
- 5) Send a copy of all minutes of meetings of Affiliated Associations to the OBA Office within 30 days of the meeting.
- 6) Notify the OBA Office as to the date, time and place of the Annual Meeting of the Affiliated Association 30 days prior to the meeting.
- 7) Pay annual affiliation fees, certificate tax and other fees according to Article 2.02 and 2.03 of the Constitution of the OBA.
- 8) Determine team classifications according to Article 2.04 of the Constitution of the OBA.
- 9) Process playing rosters according to the Constitution of the OBA.
- 10) Notify the OBA Chair of each series as to the play-off representatives from the Affiliated Association.
- 11) Approve tournament requests prior to submission to the OBA.
- 12) Approve clinic requests prior to submission to the OBA.



Rally Cap



The goals of the Baseball Canada Rally Cap program are to:

1. Create an environment in which children and adults can have fun with baseball
2. Teach baseball skills, rules and strategy to our players
3. Model and teach competitiveness with an emphasis on good sportsmanship
4. Promote increased self-esteem among Rally Cap children and adults

Rally Cap is designed to work on the 5 FUNdamentals of baseball.

We encourage local associations to hold “Rally Cap Days” to create interest in the program.

During Rally Cap events, players go through stations where they perform different tasks. When a player succeeds at each task at a particular level, he/she will be awarded an appropriate coloured hat.

If you would like more information on how to get Rally Cap into your local association, please visit www.baseballontario.com or call Baseball Ontario at 519-740-3900!

APPENDIX “B”

AFFILIATED ASSOCIATIONS

Algoma Baseball Association	ABA
Central Ontario Baseball Association	COBA
Eastern Ontario Baseball Association	EOBA
Hamilton and District Baseball Association	HDBA
Inter-County Baseball Association	ICBA
London District Baseball Association	LDBA
North Bay Baseball Association	NBBA
North Central Baseball Association	NCBA
National Capital Senior Baseball Association	NCSBA
Niagara District Baseball Association	NDBA
Southern Counties Baseball Association	SCBA
Sun Parlour Baseball Association	SPBA
Timmins Area Baseball Association	TABA
Toronto Baseball Association	TBA
Thunder Bay Baseball Association	TBBA
Western Counties Baseball Association	WCBA
Western Ontario Baseball Association	WOBA
York Simcoe Baseball Association	YSBA

AFFILIATED ASSOCIATION BOUNDARIES TERRITORIAL RIGHTS: REVISED NOVEMBER, 2003

ABA ALGOMA BASEBALL ASSOCIATION:

Starting at, but excluding Massey on #553, then North on Highway # 553, excluding all area on said Highway, then on a straight line due West to Highway #129, then North on #129, including the Town of Chapleau, then on Highway #101 to Wawa and Lake Superior, then South along Lake Superior to Sault Ste. Marie, then East along Highway #17 to Massey.

COBA CENTRAL ONTARIO BASEBALL ASSOCIATION:

(Formerly Halton County Baseball Association)

Starting at Lake Ontario, North along the Etobicoke Creek (Peel/York County Border) to Highway #50, then North on Highway #50 (excluding Bolton) to Highway #9, then West on Highway #9 (including Orangeville) to County Road leading to Fergus, then South on Highway #6, (excluding Guelph) to Highway #24, then South on Highway #24 to Highway #99 (excluding all centres), then East to Hamilton City Limits (excluding Dundas) to Lake Ontario, then East along Lake Ontario to starting point.

EOBA EASTERN ONTARIO BASEBALL ASSOCIATION:

The territory governed by the Eastern Ontario Baseball Association and approved by the Ontario Baseball Association shall begin at Lake Ontario and the Rouge River, north along the Rouge River to Highway 2; thence east along Highway 2 including the City of Pickering and the Towns of Ajax and Whitby to Region of Durham Road 23; thence north along Durham Road 23 to Highway 48; thence north and east along Highway 48 to Highway 35; thence North on Highway 35 to Minden; thence east on Highway 121 to Bancroft; thence south on Highway 62 to Madoc; thence east on Highway 7 to Sharbot Lake; thence south on Highway 38 to and including the City of Kingston, Howe Island, Wolfe Island, and Amherst Island; thence west along the shore of Lake Ontario including Prince Edward County to the starting point at the Rouge River.

HDBA HAMILTON & DISTRICT BASEBALL ASSOCIATION:

Starting at Lake Ontario, West along the Northern Boundaries of the City of Hamilton (including Dundas), South along the Hamilton-Wentworth Region boundary (including Ancaster) and East to Lake Ontario (including Glanbrook and Stoney Creek).

- ICBA INTER COUNTY BASEBALL ASSOCIATION:**
Starting at Highway 2 (Governors Road) and Highway 19 (Plank Line), excluding Thamesford; then east on Highway 2 to Oxford County Road 6 (Foldens Road); south on County Road 6 to County Road 12 (Sweaburg Road); then East on Sweaburg Road and south on Rural Road (Cedar Line) to Curries Road, east on Curries Road to Muir Line (Brant-Oxford County Line); north on Muir Line to Highway 53; then east on highway 53, including Brantford, to the boundary of Greater Hamilton; then northwest along the boundary to Highway 99; west along Highway 99 to Highway 24; then north on Highway 24 including Cambridge, Guelph and all centres on Highway 24 to Highway 7; thence west on Highway 7 including Bridgeport, Kitchener, Waterloo and Stratford, but excluding New Hamburg to Highway 19; then south on Highway 19 to Highway 2. Please note: St. Thomas Junior and Senior remain in the ICBA.
- LDDBA LONDON DISTRICT BASEBALL ASSOCIATION:**
Starting at, but excluding Port Bruce on Lake Erie, North on County Road 73 (Imperial Road) to County Road 45 (John Wise Line); west on County Road 45 to County Road 35 (Springwater Road); north on County Road 35 to County Road 52 (Ron McNeil Line); East on County Road 52 to County Road 73 (Imperial Road); North on County Road 73, across Highway 401, north to Highway 2 (Dundas St.); East on Highway 2 to Highway 19, including Thamesford; North on Highway 19 to Highway 7, then west on Highway 7, excluding St. Mary's to Highway 81 including Strathroy to and along County Road to Christena on Highway 2 to and including Melbourne, then south along County Road leading to and including Port Talbot on Lake Erie.
- NBBA NORTH BAY BASEBALL ASSOCIATION:**
Starting at the Northern most point of Highway #539-A, but excluding any location on it and going due East to Temagami on Highway #11 to the Ottawa River, then South along the Ottawa River to the Northern boundary of the National Capital Senior Baseball Association, thence along the Northern boundary of Algonquin Park to the York Simcoe Baseball Association's Northern boundary, then due East on Highway #518 to Highway #69, but excluding any location on Highway #69, then due North to Warren, and excluding any location of this line including Warren.
- NCBA NORTH CENTRAL BASEBALL ASSOCIATION:**
Starting at Massey on the West, then North to the end of Highway #553, then due East to the end of Highway #539-A, then South through a point on Highway #17 at Warren to a Southern limit on Highway #69, excluding Parry Sound, then due West from Georgian Bay to include all of the Manitoulin Islands.
- NCSBA NATIONAL CAPITAL SENIOR BASEBALL ASSOCIATION:**
The territory governed by the National Capital Senior Baseball Association shall be the newly incorporated city of Ottawa. Also included are the Counties of Dundas, Glengarry, Grenville, Lanark, Leeds, Prescott, Renfrew, Russell and Stormont. The legal description of the territory (by the Province of Ontario), shall be: the most southerly shores of the Ottawa River to the north; the Ontario-Quebec border, to the east; the most northerly shores of the St. Lawrence River, to the south; the most easterly boundaries of Hastings-Frontenac-Lennox and Addington and the most easterly boundary of Nipissing, to the west.
- NDBA NIAGARA DISTRICT BASEBALL ASSOCIATION:**
Starting at the Niagara River, then South along the Niagara River to Lake Erie, then West along the shore of Lake Erie to and including Port Maitland, then North along County Road to Highway #3, then along Highway #3 (including Dunnville and Cayuga) to Highway #54, then North on Highway #54 to Highway #6 (excluding Caledonia), then North on Highway #6 to the Boundary of the Region of Hamilton-Wentworth, then East and South along the boundary of Hamilton-Wentworth to Lake Ontario, then East along the shore of Lake Ontario to the Niagara River.
- SCBA SOUTHERN COUNTIES BASEBALL ASSOCIATION:**
Starting at Port Maitland, north along County Road to Highway 3, excluding Dunnville and Cayuga, to Highway 54; then north on Highway 54 to and including Caledonia; then north on Highway 6 to the boundary of the former Region of Hamilton-Wentworth; then west along the boundary of Hamilton-Wentworth to Highway 99; then west along Highway 99 to Highway 24; then south on Highway 24, excluding Brantford; then west along the former Highway 53 to Muir Line (Brant-Oxford County Line); south on Muir Line to Curries Road; west on Curries Road and north on Rural Road (Cedar Line) to Sweaburg Road (Oxford Rd 12). Turn west on Sweaburg Road to Oxford Road 6 (Foldens Road). Turn north on Oxford Road 6 to Highway 2 (Governors Road). Proceed west on Governor's Road, excluding Thamesford, to County Road 73 (Elgin Road); south on County Road 73 to Elgin County Road 52 (Ron McNeil Line); west on County Road 52 to County Road 35 (Springwater Road); south on County Road 35, across Highway 3, to County Road 45 (John Wise Line); then East on County Road 45 to County Road 73 (Imperial Road); south on County Road 73 to Lake Erie, including Port Bruce.
- SPBA SUN PARLOUR BASEBALL ASSOCIATION:**
Starting and including Essex County, the entire Townships of Romney and Tilbury East and that part of Raleigh Township, West of Kent County Road #6 and South of Kent County Road #14 of the County of Kent.

- TABA TIMMINS AREA BASEBALL ASSOCIATION:**
For the purpose of boundaries, the T.A.B.A. considers the Kirkland Lake area to be, the Town of Kirkland Lake and all communities and rural areas within 25 mile radius plus the city of Timmins and all communities and rural areas within 25 mile radius of that city.
- TBA TORONTO BASEBALL ASSOCIATION:**
Everything within the boundaries of the County of York which is South of Steeles Avenue and Markham Town Road or an Easterly extension thereof.
- TBBA THUNDER BAY BASEBALL ASSOCIATION:**
Starting at, and including White River on Highway #17, then North to, and including, Manitouwadge, Caramac, and Long Lac, then on a line due West on Highways 11 and #580, thence West from the terminus of Highway #580 to, and including English River, thence South on a straight line (91') to the International Boundary, then east along the Boundary and Lake Superior to, and including Heron Bay, then East on a straight line to White River.
- WCBA WESTERN COUNTIES BASEBALL ASSOCIATION:**
Includes all territory East of the following boundaries, starting at Kent County Road #6 and Kent County Road #14 of the County of Kent to the following Eastern boundaries, starting at and excluding Port Talbot on Lake Erie, North on County Road, to Highway #2, East on Highway #2 to and excluding Christena, then North along County Road to Highway #81, then North along Highway #81 excluding Strathroy to and excluding Grand Bend on Lake Huron.
- WOBA WESTERN ONTARIO BASEBALL ASSOCIATION:**
Starting at and including Grand Bend on Lake Huron, South on #81 to #7, then East along 37 (and the St. Mary's by-pass to include St. Mary's) and excluding Stratford, Kitchener and Waterloo, but including New Hamburg to #6, then North on #6 (excluding Guelph but including all other centres) to and including Fergus, then Northeast along county road to #9, then East to but excluding Orangeville, then North on #10 to Georgian Bay including all centres except Shelburne.
- YSBA YORK SIMCOE BASEBALL ASSOCIATION:**
Starting at Steeles Avenue and Highway #50, North on Highway #50 including Bolton to Highway #9, West on Highway #9 to and including Orangeville, then North on Highway #10 to Georgian Bay including Shelburne, but excluding all other centres, then Easterly along the shoreline to and including Parry Sound, then East along Highway #518 to Sand Lake, then due East to Algonquin Provincial Park boundary, then South along boundary to Highway #60, then Southerly along Highway #60 to Highway #35, then South along Highway #35 to Highway #46, then along Highway #46 to and excluding Bolsover, then along Highway #48 and #48B excluding Beaverton and Cannington to Highway #12, then South on Highway #12 to and excluding Whitby, then East along County Road in line with Markham Town Road, then along Markham Town Road and Steeles Avenue to starting point.